

KM-F1060

Operating Instructions

(For Facsimile and Copy Functions)

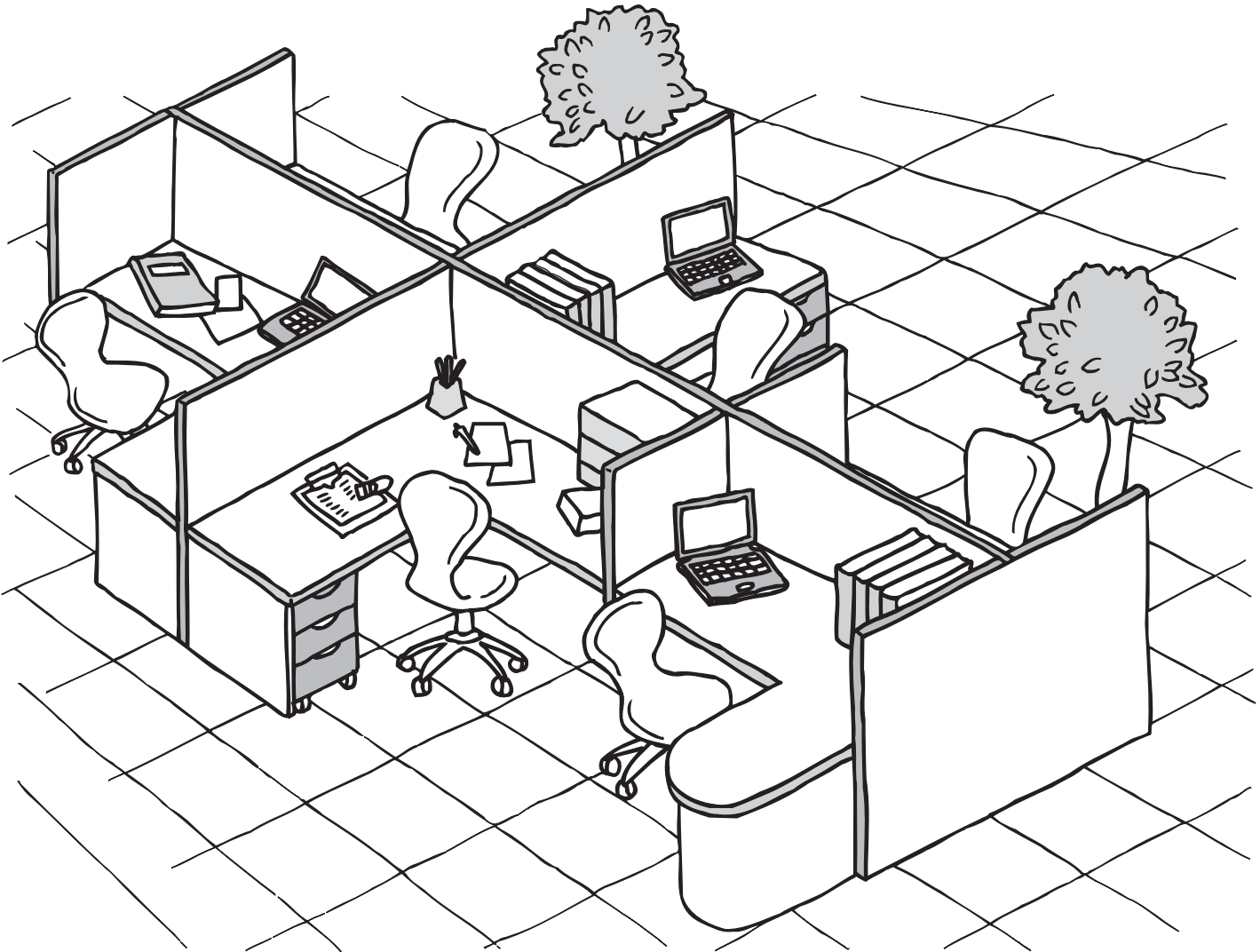

Before operating this equipment, please read these instructions completely and keep these operating instructions for future reference.



Getting To Know Your Machine

Useful Office Functions

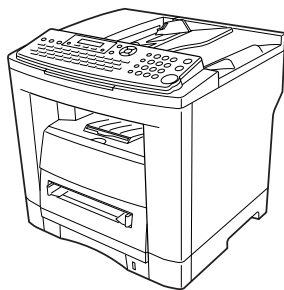

Fax

- Plain Paper High-speed Super G3 compatible Fax with JBIG compression

Copy

- Copy up to Legal size originals
- Capable of copying text/photos/halftone originals

Email

- Email Function capability when the optional Internet Fax/Email/Network Scanner Module is installed

Scan or File

- Scanner capability when the optional Internet Fax/Email/Network Scanner Module is installed
- Scanning resolution up to 600 dpi

Print

- Printer controller standard, Printer resolution 300 or 600 dpi

Application Software

- Document Manager
- Document Viewer
- Network Scanner
- Utilities (Network Status Monitor, Address Book Editor, Network Configuration Editor)
- Document Fax

The following Operating Instructions are included in the CD and refer it for detailed information.

<Facsimile and Copy>

Use the information provided on the enclosed CD (Operating Instructions) for a Facsimile and Copy function requires intervention.

For example: How to send/receive a Fax, make copies, add paper, replace the toner container, etc.

<Internet Fax/Email and Network Scan>









Use the information provided on the enclosed CD (Operating Instructions) for an optional Internet Fax/Email and Network Scan functions.

For example: How to send/receive a Email/Scanned Document(s), or when a trouble message appears, etc.

<Print & Other Advanced Functions>

Use the information provided on the enclosed CD (Document Management System) for Network Printer, Editing Directory Dialing Feature, Device Settings, Network Status Monitor, and/or Document Management System.

Operating Instructions Outline

- 
Getting To Know Your Machine
 - Precautions (See pages 9-19)
 - Quick Operation Chart, Adding Paper (See pages 22-27)
 - Problem Solving, Memory Capacity, Replacing Toner Container, Removing a Misfed Paper, Error Codes (U Code/J Code) (See pages 27-33)
- 
Before Starting
 - Control Panel Key/Indicator Names (See pages 36, 37)
- 
Facsimile Features
 - Operating Instructions for facsimile (See pages 38-87)
- 
Copy Features
 - Operating Instructions for making copies (See pages 88-93)
- 
Setting Your Machine
 - Changing the Initial Machine Modes
 - General, Copier, Printer and Scanner Settings (See pages 94-121)
- 
Printing Journals and Lists
 - Transaction Journal (See pages 122, 123)
 - Communication Journal (See pages 124, 125)
 - One-Touch/Abbreviated and Directory Search List (See pages 126, 127)
 - Program List (See pages 128, 129)
 - Fax Parameter List (See pages 130, 131)
- 
Problem Solving
 - Troubleshooting/Machine Care (See pages 132-137)
 - Set the Date and Time (See page 106)
 - Replacing the Battery (See page 137)
- 
Appendix
 - Specifications, Options and Supplies, etc. (See pages 138-149)



Getting To Know Your Machine

Symbols/Icons

The following Symbols/Icons are used throughout the Operating Instructions.



Place original(s) on the ADF



Press any Key on the Control Panel

Press Key



Input numbers

- Dialing, Number of Copies, etc.

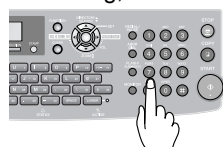

Input text with QWERTY keyboard

- Station Name, Directory Search, etc.



Go to next step



Go to next step (below)



Getting to know your machine Before starting



When sending/receiving document(s)

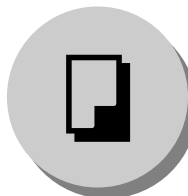

When making copies

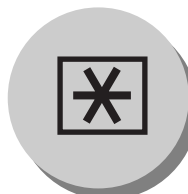

When setting the machine modes



When printing the journals or lists



Problem solving



Appendix (Specifications, Index)

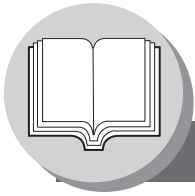

Getting To Know Your Machine

Table of Contents

Getting To Know Your Machine

Useful Office Functions	2
Operating Instructions Outline	3
Symbols/Icons	4
Precautions	9
■ For Your Safety.....	9
■ Installation and Relocation Cautions.....	9
■ Power and Ground Connection Cautions	9
■ Others	10
■ Operating Safeguards.....	10
■ Others	11
■ Consumable Safeguards	11
■ For Your Safety.....	12
■ Supplies	12
■ Installation.....	12
■ Illegal Copies	12
■ Ventilation	13
■ Handling.....	13
■ Laser Safety	14
■ Caution Label.....	14
■ FCC Notice for Users in USA.....	16
■ Notice to Users in Canada	18
Connecting the Cables	20
Directory Search and Quick Name Search	21
Dual G3 Communication Port with Optional G3 Communication Port Kit	21
Operation Chart	22
■ Sending Documents.....	22
■ To Stop the Transmission	24
■ Making Copies	24
■ Using the ADF.....	24
■ Copying onto Transparency Film (OHP), Thick (Heavy) Paper Stock, etc. (except Thin paper)	25
■ Adding Paper (Paper Trays: Tray-1 and Tray-2)	26
■ Adding Paper (Sheet Bypass).....	26
■ Problem Solving.....	27
Mode Setting	34
■ Using the Functions	34
Control Panel	36

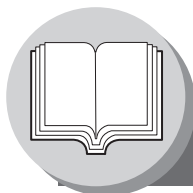

Getting To Know Your Machine

Table of Contents

Facsimile Features

Sending Documents	38
■ General Description	38
■ Memory Transmissions.....	38
■ To Stop the Transmission.....	39
■ Using One-Touch Dialing.....	40
■ Redialing the Last Dialed Numbers	40
■ Direct Transmission Reservation (Priority Transmission Reservation).....	42
■ Canceling the Direct Transmission Reservation.....	43
■ Duplex Sending	44
■ On-Hook Dialing	46
■ Off-Hook Dialing (Voice Mode Transmission).....	46
Receiving Documents	48
■ Automatic Reception.....	48
■ Manual Reception.....	48
■ Substitute Memory Reception.....	48
■ Print Reduction Setting	48
■ 2-Sided Receiving.....	49
Timer Controlled Communications	50
■ General Description	50
■ Deferred Transmission	50
■ Deferred Polling	50
Batch Transmission	52
■ General Description	52
■ Real-Time Batch Transmission.....	52
Polling	54
■ General Description	54
■ Preparing to be Polled	54
■ Poll Documents from Another Station.....	56
Program Keys	58
■ General Description	58
■ Setting for Group Dialing	58
■ Changing the Group Dialing	58
■ Setting Programmed Communication.....	60
■ Changing the Program Key Setting	60
Sub-Addressing	62
■ Sending a Fax with Sub-Address	62
■ Setting the Sub-Address into an Address Book.....	62
Fax Cover Sheet	64
■ Using the Fax Cover Sheet.....	64
Receive To Memory	66
■ Setting RCV To Memory Password	66
■ Setting the RCV To Memory.....	66
■ Printing Documents	66
PIN Code Access	68
■ General Description	68
■ Selecting the Access Method (Prefix or Suffix).....	68
■ Dialing with a PIN Code.....	68

Facsimile Features

Department Code	70
■ General Description	70
■ Setting the Department Code	70
■ Changing or Erasing the Department Code	72
■ Sending Document with Department Code	72
■ Printing a Department Code Journal	74
Edit File Mode	76
■ General Description	76
■ Printing or Viewing a List	76
■ Changing the Start Time or the Station of a File	78
■ Deleting a File	78
■ Printing Out a File	80
■ Adding Documents into a File	80
■ Retry an Incomplete File	82
Access Code	84
■ General Description	84
■ Setting the Access Code	84
■ Operating FAX with the Access	84
Dial Prefix	86
■ General Description	86
■ Setting the Dial Prefix	86

Copy Features

Basic Copy	88
■ Copying the Same Size Originals (1:1)	88
■ Multi-Size Feeding (MIX)	88
■ Sort Mode	88
■ Copying with Variable or Preset Zoom Ratios	88
■ Using the ADF	89
Creative Features	90
■ 1→2 Copy	90
■ 2→2 Copy, 2→1 Copy	90
Other Features	92
■ Changing the Paper Size (Sheet Bypass)	92
■ Energy Saver (Power Saver Mode, Sleep/Shutdown Mode)	92

Setting Your Machine

Adjusting the Volume and Dialing Method (Tone or Pulse)	94
■ Setting the Dialing Method (Tone or Pulse)	94
■ Setting the Monitor Volume	94
■ Setting the Ringer Volume	94



Getting To Know Your Machine

Table of Contents

Setting Your Machine

Programming Auto Dialer	96
■ General Description	96
■ Programming Address Book Dialing.....	96
■ Entering One-Touch Dialing Numbers.....	98
■ Entering Abbreviated Dialing Numbers.....	98
■ Printing the Directory Sheet.....	100
■ Address Book Modification	102
■ Address Book Deletion	102
■ Changing or Erasing the Settings of the One-Touch/ Abbreviated Dialing Numbers	104
User Parameters (For Facsimile)	106
■ General Description	106
■ Setting the User Parameters	106
Fax Parameters	108
■ General Description	108
■ Setting the Fax Parameters	108
Copier Parameters	116
■ Setting the Copier Parameters	116
■ Copier Settings	116
■ Copier Settings (For Key Operator)	117
Changing the Paper Size	118
■ Changing the Paper Size (Paper Tray).....	118
Changing the Original Size	120
■ Changing the Default Original Size (For Copier)	120

Printing Journals and Lists

Transaction Journal	122
Communication Journal (COMM. JOURNAL)	124
One-Touch/Abbreviated and Directory Search List	126
Program List	128
Fax Parameter List	130

Problem Solving

Troubleshooting / Maintenance	132
Information Code	134
Verification Stamp	137
■ Verification Stamp.....	137
■ Replacing the Battery	137

Appendix

Specifications	138
Glossary	142
ITU-T Image No. 1	147
Index	148

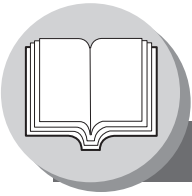

Getting To Know Your Machine

Precautions

For Your Safety

To prevent severe injury and loss of life, read this section carefully before using your machine to ensure proper and safe operation of your machine.

- This section explains the graphic symbols used in this manual.



WARNING:

Denotes a potential hazard that could result in serious injury or death.



CAUTION:

Denotes hazards that could result in minor injury or damage to the machine.

- This section also explains the graphic symbols used in this manual.



These symbols are used to alert operators to a specific operating procedure that must not be performed.



These symbols are used to alert operators to a specific operating procedure that must be emphasized in order to operate the machine safely.

Installation and Relocation Cautions

CAUTION



Do not place the machine near heaters or volatile, flammable, or combustible materials such as curtains that may catch fire.



Do not place the machine in a hot, humid, dusty or poorly ventilated environment. Prolonged exposure to these adverse conditions can cause fire or electric shocks.



Place the machine on a level and sturdy surface that can withstand a weight of 48.5 lb (22 kg). If tilted, the machine may tip-over and cause injuries.



When relocating the machine, contact your authorized dealer.



When moving the machine, be sure to unplug the power cord from the outlet. If the machine is moved with the power cord attached, it can cause damage to the cord which could result in fire or electric shock.

Power and Ground Connection Cautions

WARNING



Ensure that the plug connection is free of dust. In a damp environment, a contaminated connector can draw a significant amount of current that can generate heat and eventually cause fire over an extended period of time.



Always use the power cord provided with your machine. When an extension power cord is required, always use a properly rated cord.

- 120 V/15 A

If you use a cord with an unspecified current rating, the machine or plug may emit smoke or become hot to the touch externally.



Do not attempt to rework, pull, bend, chafe or otherwise damage the power cord. Do not place a heavy object on the cord. A damaged cord can cause fire or electric shocks.



Never touch a power cord with wet hands. Danger of electric shock exists.



If the power cord is broken or insulated wires are exposed, contact your authorized dealer for a replacement. Using a damaged cord can cause fire or electric shocks.

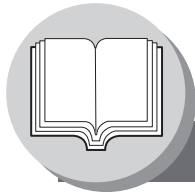

Getting To Know Your Machine

Precautions



Stop operation immediately if your machine produces smoke, excessive heat, unusual noise, or smell, or if water is spilled onto the machine. These conditions can cause fire. Immediately switch Off and unplug the machine, and contact your authorized dealer.



Do not disconnect or reconnect the machine while it is on. Disconnecting a live connector can deform the plug and cause fire.



When disconnecting the machine, grasp the plug instead of the cord. Forcibly pulling on a cord can damage it and cause fire or electric shock.



When the machine is not used over an extended period of time, switch it Off and unplug it. If an unused machine is left connected to a power source for a long period, degraded insulation can cause electric shocks, current leakage or fire.



Be sure to switch Off and unplug the machine before accessing the interior of the machine for cleaning, maintenance or fault clearance. Access to a live machine's interior can cause electric shock.



Be sure to switch Off and unplug the machine before accessing the interior of the machine for accessing interface cables, maintenance or fault clearance. Access to a live machine's interior can cause electric shock.



Once a month, unplug the machine and check the power cord for the following. If you notice any unusual condition, contact your authorized dealer.

- The power cord is plugged firmly into the receptacle.
- The plug is not excessively heated, rusted, or bent.
- The plug and receptacle are free of dust.
- The cord is not cracked or frayed.

Others

- The machine has a built-in circuit for protection against lightning-induced surge current. However, if lightning strikes in your neighborhood, switch Off the machine. Disconnect the power cord from the machine and reconnect only when the lightning has stopped.
- If you notice flickering or distorted images or noises on your audio-visual units, your machine may be causing radio interference. Switch it Off and if the interference disappears, the machine is the cause of the radio interference. Perform the following procedure until the interference is corrected.
 - Move the machine and the TV and/or radio away from each other.
 - Reposition or reorient the machine and the TV and/or radio.
 - Unplug the machine, TV and/or radio, and replug them into outlets that operate on different circuits.
 - Reorient the TV and/or radio antennas and cables until the interference stops. For an outdoor antenna, ask your local electrician for support.
 - Use a coaxial cable antenna.

Operating Safeguards

WARNING



Do not touch areas where these caution labels are attached to the surface may be very hot, and cause severe burns.



Do not place any liquid container such as a vase or coffee cup on the machine. Spilt water can cause fire or shock hazard.



Do not place any metal parts such as staples or clips on the machine. If metal and flammable parts get into the machine, they can short-circuit internal components, and cause fire or electric shocks.



If debris (metal or liquid) gets into the machine, switch Off and unplug the machine. Contact your authorized dealer. Operating a debris-contaminated machine can cause fire or electric shock.











Never open or remove machine covers that are secured with screws unless specifically instructed in the "Operating Instructions". A high-voltage component can cause electric shocks.



Do not try to alter the machine configuration or modify any parts. An unauthorized modification can cause smoke or fire.



⚠ CAUTION

-  Do not place a magnet near the safety switch of the machine. A magnet can activate the machine accidentally, resulting in injuries.
-  Do not use a highly flammable spray or solvent near the machine. It can cause fire.
-  Never touch a labelled area found on or near the heat roller. You can get burnt. If a sheet of paper is wrapped around the heat roller, do not try to remove it yourself to avoid injuries or burns. Switch Off the machine immediately, and contact your authorized dealer.
-  Do not use conductive paper, e.g. folding paper, carbonic paper and coated paper. When a paper jam occurs, they can cause a short circuit and fire.
-  Do not place any heavy object on the machine. An off-balance machine can tip-over or the heavy object can fall, causing damage and/or injuries.
-  Keep the room ventilated when using the machine for an extended period of time to minimize the ozone density in the air.
-  Pull out paper trays slowly to prevent injuries.
-  When removing jammed paper, make sure that no pieces of torn paper are left in the machine. A piece of paper remaining in the machine can cause fire. If a sheet of paper is wrapped around the heat roller, or when clearing a jammed paper that is difficult or impossible to see, do not try to remove it by yourself. Doing so can cause injuries or burns. Switch Off the machine immediately, and contact your authorized dealer.



Others

- When clearing a paper jam or other fault, follow the appropriate procedure given in the Operating Instructions.

Consumable Safeguards**⚠ WARNING**

-  Never throw a toner container into an open flame. Toner remaining in the container can cause an explosion and you can get burnt.
-  Never throw toner or a waste toner container or a toner container into an open flame. It can cause an explosion and you can get burnt.
-  Keep button batteries/verification stamp out of the reach of children. If a button battery/stamp is swallowed accidentally, get medical treatment immediately.

⚠ CAUTION

-  Never heat the drum container, or scratch its surface. A heated or scratched drum can be hazardous to your health.
-  Be sure to use the specified type of batteries only.
-  Ensure that batteries are installed with correct polarity. Incorrectly installed batteries can burst or leak, resulting in spillage or injuries.



Getting To Know Your Machine

Precautions

For Your Safety

- The maximum power consumption is 1000 W.
A properly wired (grounded), dedicated, 15A, 120V AC outlet is required. Do not use an extension cord.
The power cord on this machine must be used to disconnect the main power.
Please ensure that the machine is installed near a wall outlet and is easily accessible.

Caution Note: Unplug the power cord from the wall outlet before removing covers.

Supplies

- Store the Toner Container and paper in cool areas with low humidity.
 - We recommend using high quality 16 - 28 lb paper (Sheet Bypass: 16 - 44 lb), using an inferior paper may cause excessive paper curl, requiring you to empty out the Output Tray more often to avoid paper jams.
 - For optimum performance, it is recommended that only our Brand supplies are used in the machine.
 - Certain types of transparency film may not be compatible and may damage your machine.
Consult with an authorized dealer for advice regarding non-standard paper types.
(We have tested "3M CG3300" transparency film and found it to be compatible.)
- Use of other than genuine our supplies can damage the printer. Be sure to use only genuine Toner Container (TD-47) designed for optimum performance.
Average yield for the TD-47 is approximately 5,000 pages (5% coverage).

Note: Average yield is based on 5% coverage of the printable area with repetitive printing of 10 pages (Letter/A4 size, single side printing, default density). The yield of a Toner Container varies depending on the coverage, temperature, humidity, media, etc. Therefore, the average yield cannot be guaranteed. Continuously printing 10% coverage of printable area will reduce the yield of the Toner Container to about half as compared to 5% coverage printing. The maximum yield of the Toner Container will not exceed 6,000 pages.

Installation

- The machine should not be installed in areas with the following conditions:

- Extremely high or low temperature and humidity.

Ambient conditions:

Temperature: 50 – 86 °F

Relative humidity: 30 – 80 %

- Where temperature and humidity can change rapidly, causing condensation.
- Direct exposure to sunlight.
- In areas of high dust concentration.
- In areas with chemical fume concentration.
- With unstable or uneven conditions (floors, etc.).
- Directly in the air conditioning flow.
- In areas of poor ventilation.
- In areas with extreme vibration.

Illegal Copies

It is unlawful to make copies of certain documents.

Copying certain documents may be illegal in your country. Penalties of fines and/or imprisonment may be imposed on those found guilty. The following are examples of items that may be illegal to copy in your country.

- Currency
- Bank notes and checks
- Bank and government bonds and securities
- Passports and identification cards
- Copyright material or trademarks without the consent of the owner
- Postage stamps and other negotiable instruments

This list is not inclusive and no liability is assumed for either its completeness or accuracy. In case of doubt, contact your legal counsel.

Notice:

Install your machine near a supervised area to prevent illegal copies from being made.

Ventilation

- The machine should be installed in a well-ventilated area to minimize the ozone density in the air.

Handling

- Do not turn the Power Switch Off or open the Front Cover during copying/printing.
- Energy Saver Mode Notice
 - When using the Printer Function (USB Local and Network Connections), we recommend that you leave the Energy Saver Mode in the initial factory default setting (Sleep mode). (See page 92)
- Key Operator Password
 - The Initial Machine Modes can be checked or changed with the Function Modes, however, these modes require the Key Operator Password.

For Key Operator: When setting up this machine, please consult with your authorized dealer, and decide on the Key Operator Password together, then record it and keep it in a safe place for future reference.
- Dept. (DEPARTMENT) Code



1 to 8-digit

When the Department Counter function is set up, the Dept. (Department) Code input screen is displayed on the LCD Display. A registered Department Code (1 to 8-digit) is required to gain access to each secured function, or the secured Fax/Scanner function(s) cannot be used. Please consult with the Key Operator regarding the Department Code(s) for the desired function.

Procedures:

- (1) Input a registered department code (1 to 8-digit).
- (2) Press the SET or START Key.

- Number of Copies

The maximum number of copies is up to 999 (3 digit with keypad). During the copy mode, if you input 4-8 digit numbers, they will be interpreted as being a phone number and displayed on the LCD, then the machine will switch to the Fax mode.
- Auto Reset Timer

As the initial setting for Auto Reset Time is 1 minute, selected operation mode returns to default operation mode (Fax) after 1 minute, if you wish to change this Auto Reset Time, set to Fax Parameter No.121. (See pages 113).



Getting To Know Your Machine

Precautions

■ Laser Safety

LASER SAFETY

This machine employs a laser. Only qualified service personnel should attempt to service this device due to possible eye injury.

CAUTION:

USE OF CONTROLS, ADJUSTMENTS OR PERFORMANCE PROCEDURES OTHER THAN THOSE SPECIFIED HEREIN MAY RESULT IN HAZARDOUS RADIATION EXPOSURE.



■ Caution Label

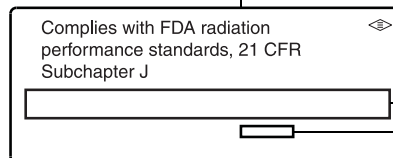
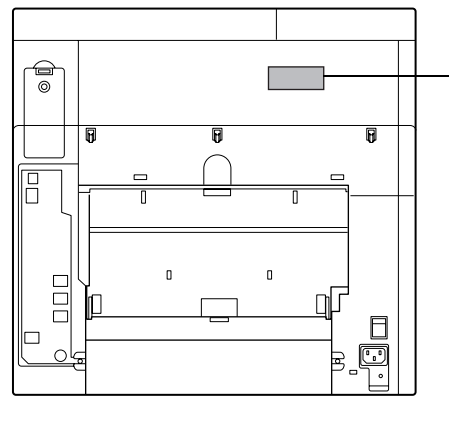
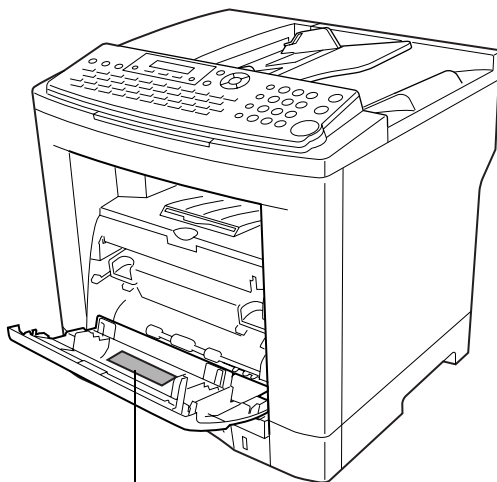

Manufacturer's
Name and Address
Factory ID

CAUTION : CLASS 3B INVISIBLE LASER RADIATION WHEN OPEN AND INTERLOCKS DEFEATED. AVOID EXPOSURE TO THE BEAM.
ATTENTION : Rayonnement laser classe 3B invisible en cas d'ouverture et de défaut de sécurité. EXPOSITION DANGEREUSE AU FAISCEAU.
Vorsicht : Um bei geöffnetem Deckel den Austritt von Klasse 3B unsichtbare Laserstrahlung zu verhindern, muss die Stromversorgung des Lasers unterbrochen werden.
PRECAUCIÓN : RADIACIÓN LASER DE CLASE 3B INVISIBLE CUANDO SE ABRE LA PUERTA CON EL BLOQUEO INVALIDADO. EVITE LA EXPOSICIÓN A LOS RAYOS.
VAROITUS : LUOKKA 3B NÄKYMÄTÖNTÄ JA VAARALLISTA LASERSÄTEILYÄ, JOS LAITTEEN KANSI AVATAAN KESKEN SKANNAUKSEN JA SUOJALUKITUS OHITETAAN. VÄLTÄ SUORAA ALTISTUMISTA SÄTEELLE.
ADVARSEL : KLASSE 3B USYNLIG LASERSTRÅLING NÅR ÅBEN OG SIKKERHEDSLÅS BRYDES. UNDGÅ EKSPONERING FOR STRÅLEN.
ADVARSEL : KLASSE 3B OSYNLIG LASERSTRÅLING NÅR MASKINEN ER ÅPEN OG SIKKERHETSLÅS BRYTES. UNNGÅ EKSPONERING FOR STRÅLEN.
VARNING : CLASS 3B OSYNLIG LASER ÖPPEN OCH NÅR SÄKERHETSPÄRRAR ÄR URKOPPLADE. UNDVIK EXPONERING AV LASER
注意 : 当打开本机及连锁装置失效时, 为防止CLASS 3B不可见激光照射, 请勿暴露在光柱下。
주의 : 커버(덮개)가 열려 있거나 인터록이 파손된 경우 눈에 보이지 않는 클래스3B의 레이저 광선이 유출될 수 있습니다. 레이저 광선에 노출되지 않도록 주의 하십시오. FBS8932B

⚠ CAUTION Denotes hazards that could result in minor injury or damage to the machine.

- TO REDUCE THE RISK OF SHOCK OR FIRE, USE ONLY NO. 26 AWG OR LARGER TELEPHONE LINE CABLE.
- DISCONNECT ALL POWER TO THE MACHINE BEFORE COVER(S) ARE REMOVED. REPLACE THE COVER(S) BEFORE THE MACHINE IS RE-ENERGIZED.

⚠ IMPORTANT SAFETY INSTRUCTIONS

When using your telephone equipment, basic safety precautions should always be followed to reduce the risk of fire, electric shock and injury to persons, including the following:

- DO NOT USE THIS PRODUCT NEAR WATER, FOR EXAMPLE, NEAR A BATH TUB, WASH BOWL, KITCHEN SINK OR LAUNDRY TUB, IN A WET BASEMENT OR NEAR A SWIMMING POOL.
- AVOID USING A TELEPHONE (OTHER THAN A CORDLESS TYPE) DURING AN ELECTRICAL STORM. THERE MAY BE A REMOTE RISK OF ELECTRIC SHOCK FROM LIGHTNING.
- DO NOT USE THE TELEPHONE TO REPORT A GAS LEAK IN THE VICINITY OF THE LEAK.

SAVE THESE INSTRUCTIONS.



As an ENERGY STAR® Partner, KYOCERA MITA AMERICA, INC. has determined that this product meets the ENERGY STAR® guidelines for energy efficiency.

This voluntary program specifies certain energy consumption and usage standards. This product will automatically "power down" after a specified period of non-use. The use of this ENERGY STAR® compliant product will reduce energy consumption and ultimately benefit the environment.

The default functions can be adjusted depending on your office requirements. Please ask your Authorized dealer for more details.



Getting To Know Your Machine

Precautions

FCC Notice for Users in USA

WARNING

This equipment has been tested and found to comply with the limits for a Class B digital device, pursuant to Part 15 of the FCC Rules. These limits are designed to provide reasonable protection against harmful interference in a residential installation. This equipment generates, uses and can radiate radio frequency energy and, if not installed and used in accordance with the instructions, may cause harmful interference to radio communications. However, there is no guarantee that interference will not occur in a particular installation. If this equipment does cause harmful interference to radio or television reception, which can be determined by turning the equipment off and on, the user is encouraged to try to correct the interference by one of the following measures:

1. Reorient or relocate the receiving antenna.
2. Relocate the fax machine with respect to receiver or other equipment.
3. Connect the fax machine into outlet on a circuit different from that to which the receiver is connected.
4. Consult the dealer or an experienced radio/TV technician for help.

Warning: To assure continued compliance, use only USB shielded interface cable when connecting this product to host computer. Also, any changes or modifications not expressly approved by the party responsible for compliance could void the user's authority to operate this equipment.

This device complies with Part 15 of the FCC Rules. Operation is subject to the following two conditions:

- (1) This device may not cause harmful interference, and
- (2) this device must accept any interference received, including interference that may cause undesired operation.

KYOCERA MITA AMERICA, INC.

225 Sand Road,
Fairfield, New Jersey 07004-0008
TEL : (093)808-8444

Note: For Technical Support, please contact your Authorized dealer.

This equipment complies with Part 68 of the FCC rules and the requirements adopted by the ACTA. On the rear panel of this equipment is a label that contains, among other information, a product identifier in the format US:AAAEQ##TXXXX. If requested, this number must be provided to the telephone company.

Ask your telephone company or installer to install the jack suitable for your device if such is not available.

A plug and jack used to connect this equipment to the premises wiring and telephone network must comply with the applicable FCC Part 68 rules and requirements adopted by the ACTA. A compliant telephone cord and modular plug is provided with this product. It is designed to be connected to a compatible modular jack that is also compliant. See installation instructions for details.

The REN is used to determine the number of devices that may be connected to a telephone line. Excessive RENs on a telephone line may result in the devices not ringing in response to an incoming call. In most but not all areas, the sum of RENs should not exceed five (5.0). To be certain of the number of devices that may be connected to a line, as determined by the total RENs, contact the local telephone company. The REN for this product is part of the product identifier that has the format US:AAAEQ##TXXXX. The digits represented by ## are the REN without a decimal point (e.g., 03 is a REN of 0.3).

If your telephone equipment causes harm to the telephone network, the Telephone Company may discontinue your service temporarily. If possible, they will notify you in advance. But if advance notice isn't practical, you will be notified as soon as possible. You will be informed of your right to file a complaint with FCC.

Your telephone company may make changes in its facilities, equipment, operations or procedures that could affect the proper functioning of your equipment. If they do, you will be notified in advance to give you an opportunity to maintain uninterrupted telephone service.

If you experience trouble with this telephone equipment, please contact the manufacturer's authorized service agency for information on obtaining service or repairs. The telephone company may ask that you disconnect this equipment from the network until the problem has been corrected or until you are sure that the equipment is not malfunctioning.

The optional Handset Kit is hearing aid compatible.

For protection against the risk of electric shock, always disconnect all cables from the wall outlet before servicing, modifying or installing the equipment.

This equipment may not be used on coin service provided by the telephone company nor connected to party lines. Connection to party line service is subject to state tariffs. (Contact the state public utility commission, public service commission or corporation commission for information.)

If your home has specially wired alarm equipment connected to the telephone line, ensure the installation of this equipment does not disable your alarm equipment. If you have questions about what will disable alarm equipment, consult your company or a qualified installer.

The Telephone Consumer Protection Act of 1991 makes it unlawful for any person to use a computer or other electronic device to send any message via telephone facsimile machine unless such message clearly contains in a margin at the top or bottom of each transmitted page or on the first page of transmission the following information:

1. Date and Time of transmission
2. Identification of either business, business entity or individual sending the message
3. Telephone number of either the sending machine, business entity or individual.

In order to program this information into your facsimile machine, you should refer to page 106 in this Operating Instructions to complete the steps.

Example of Header Format (DATE and TIME, LOGO, ID Number setting)

MMM-dd-yyyy 09:00	ABCD	201 348 7000	P.001/005
↑	↑	↑	
1) Date and Time	2) LOGO	3) ID Number	



Getting To Know Your Machine

Precautions

Notice to Users in Canada

NOTICE

Before installing this equipment, users should ensure that it is permissible to be connected to the facilities of the local telecommunications company. The equipment must also be installed using an acceptable method of connection. The customer should be aware that compliance with the above conditions may not prevent degradation of service in some situations.

Repairs to this equipment should be made by an authorized Canadian maintenance facility designated by supplier. Any repairs or alterations made by the user to this equipment, or equipment malfunctions, may give the telecommunications company cause to request the user to disconnect the equipment.

Users should ensure for their own protection that the electrical ground connections of the power utility, telephone lines and internal metallic water pipe system, if present, are connected together. This precaution may be particularly important in rural areas.

CAUTION

Users should not attempt to make such connections themselves, but should contact the appropriate electric inspection authority, or electrician, as appropriate.

NOTICE

This equipment meets the applicable Industry Canada Terminal Equipment Technical Specifications. This is confirmed by the registration number. The abbreviation, IC, before the registration number signifies that registration was performed based on a Declaration of Conformity indicating that Industry Canada Technical Specifications were met. It does not imply that Industry Canada approved the equipment.

On the rear panel of this equipment is a label that contains, among other information, the Registration Number and Ringer Equivalence Number (REN) for this equipment.

The REN assigned to each terminal equipment provides an indication of the maximum number of terminals allowed to be connected to a telephone interface. The termination on an interface may consist of any combination of devices subject only to the requirement that the sum of the Ringer Equivalence Numbers of all devices does not exceed five.

Avis

Avant d'installer ce matériel, l'utilisateur doit s'assurer qu'il est permis de le raccorder aux installations de l'entreprise locale de télécommunication. Le matériel doit également être installé en suivant une méthode acceptée de raccordement. L'abonné ne doit pas oublier qu'il est possible que la conformité aux conditions énoncées ci-dessus n'empêche pas la dégradation du service dans certaines situations.

Les réparations de ce matériel doivent être effectuées par un centre d'entretien canadien autorisé désigné par le fournisseur. La compagnie de télécommunications peut demander à l'utilisateur de débrancher un appareil à la suite de réparations ou de modifications effectuées par l'utilisateur ou à cause de mauvais fonctionnement.

Pour sa propre protection, l'utilisateur doit s'assurer que tous les fils de mise à la terre de la source d'énergie électrique, des lignes téléphoniques et des canalisations d'eau métalliques, s'il y en a, sont raccordés ensemble. Cette précaution est particulièrement importante dans les régions rurales.

Avertissement

L'utilisateur ne doit pas tenter de faire ces raccordements lui-même; il doit avoir recours à un service d'inspection des installations électriques, ou à un électricien, selon le cas.

Avis

Le présent matériel est conforme aux spécifications techniques d'Industrie Canada applicables au matériel terminal. Cette conformité est confirmée par le numéro d'enregistrement. Le sigle IC, placé devant le numéro d'enregistrement, signifie que l'enregistrement s'est effectué conformément à une déclaration de conformité et indique que les spécifications techniques d'Industrie Canada ont été respectées. Il n'implique pas qu'Industrie Canada a approuvé le matériel.

Sur le panneau arrière de cet appareil se trouve une étiquette, sur laquelle est indiqué, entre autres, le numéro d'enregistrement et le Numéro d'Equivalence de Sonnerie (REN) pour cet appareil.

L'IES assigné à chaque dispositif terminal indique le nombre maximal de terminaux qui peuvent être raccordés à une interface téléphonique. La terminaison d'une interface peut consister en une combinaison quelconque de dispositifs, à la seule condition que la somme d'indices d'équivalence de la sonnerie de tous les dispositifs n'excède pas 5.

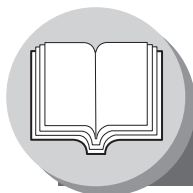

Getting To Know Your Machine

Connecting the Cables

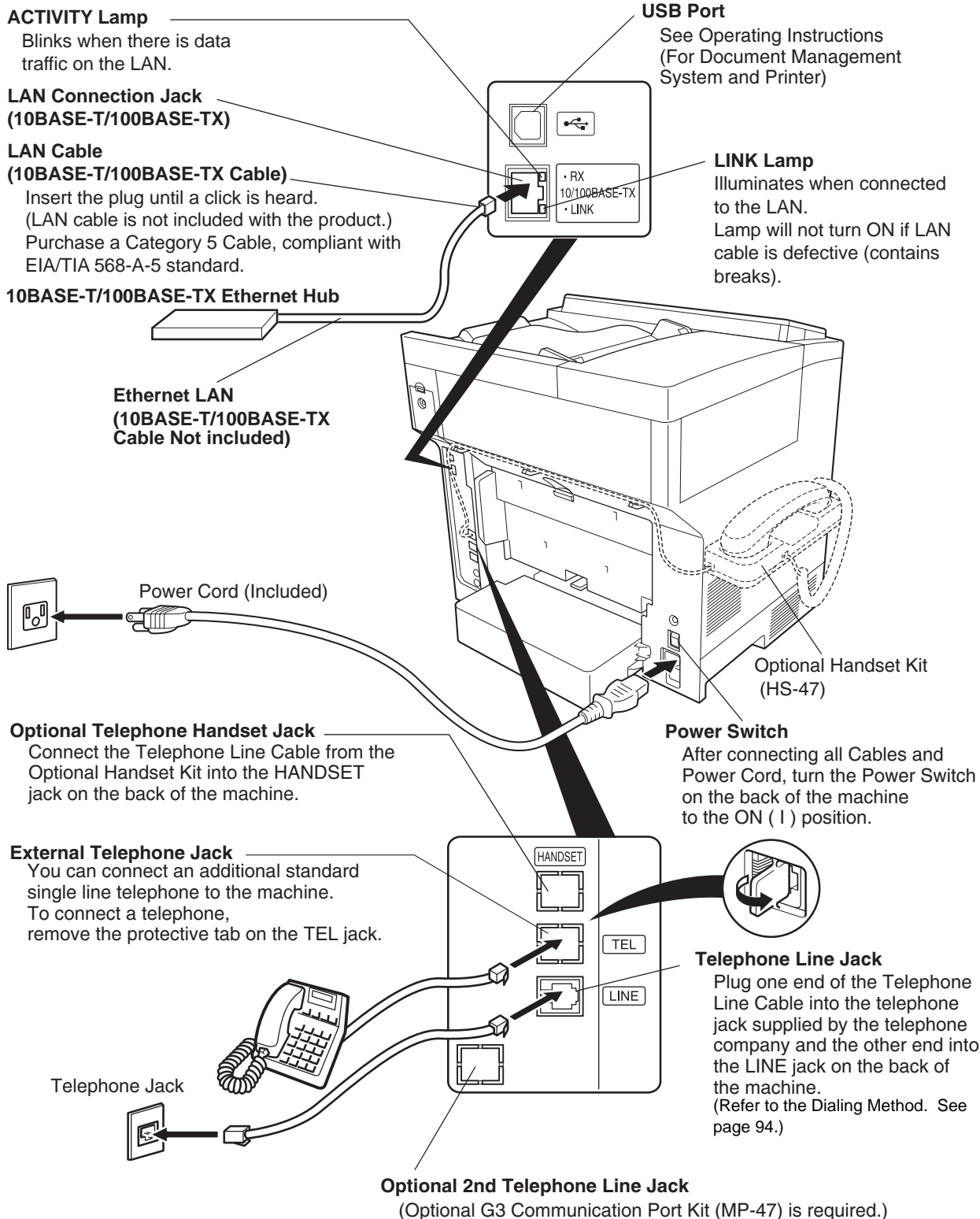

Directory Search and Quick Name Search

"**Directory Search**" function works with the following database to run the search for fax phone numbers and email addresses by name.

- LDAP Directory Server on your local area network
- Your machine's Auto-Dialer (Address Book or One-Touch/ABBR.)

If your machine is programmed with your LDAP server's address (see the User Parameters (Internet Parameters) section in Operating Instructions (For Internet Fax/Email and Network Scan Functions)) "Directory Search" runs the search with LDAP database first, and then search within the Auto-Dialer. If LDAP server is not programmed only the Auto-Dialer will be searched.

"**Directory Search**" allows the entry of multiple letters from the QWERTY keyboard to narrow down the search to quickly find the name off the large database such as LDAP server or the optional 1,000-station Auto-Dialer.

"**Quick Name Search**" function works with the machine's Auto-Dialer only. Simply by pressing the first letter of your searching name repeatedly, the names beginning with that letter appear one by one in the LCD display. This may be much easier and quicker to find your searching station than using One-Touch/ABBR. auto-dialer.

This also works to find the programmed communications such as Group Dialing, Differed Transmission and so on by name.

Dual G3 Communication Port with Optional G3 Communication Port Kit

The optional G3 Communication Port maximizes the benefit of your machine's high-speed Super G3 communication by providing you with a dual line communication capability. It's like having two faxes in one. Each line can be used independently by taking advantage of simultaneous transmission/reception or one line can be utilized exclusively for transmission and the other for reception. Either way, the waiting time to perform Multi-Transmissions will be reduced in half.

You must set the Dialing Method (Tone or Pulse) for each port when you use first. (See page 94)

By the default the machine selects the available telephone line for transmission automatically. To change the Home position of the Telephone Line Selection to either Line-1 or Line-2, change the Fax Parameter No. 88 (XMT RESTRICTION) accordingly. (See page 112)



Getting To Know Your Machine

Operation Chart

■ Sending Documents

1

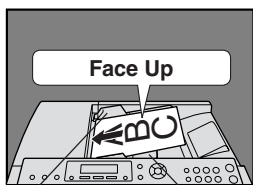

*Hold the center of the guides when adjusting the width.

NOTE:

1. You must not try to send/scan an original shorter than 4.7 inches (120 mm). See page 24 "Using the ADF".

ENTER STATION(S)
THEN PRESS START 00%

Make sure that the above message is shown on the display.
If not, press the STOP key.

Original Guides*	Max. 100 pages	Original Size:
Adjust to the original's width.	(Letter size originals)	Invoice - Legal
	(See page 24)	

3a

Quick Name Search Dialing (see Note 2)
(When Fax Parameter No. 119 is set to "2:Quick Name Search", See page 112.)



Enter the first letter of the name you wish to search repeatedly until it is shown on the LCD display.

Ex: "S"

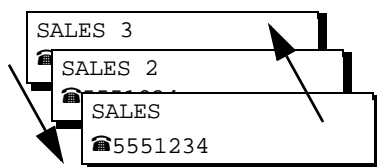

(See Note 4)



3b

One-Touch/ABBR. Dialing (see Note 2)
(When Fax Parameter No. 119 is set to "1:One-Touch", See page 112.)



(See page 40)

or



+ ABBR No.
(3-digit)



3c

Manual Number Dialing (Up to 50 Stations)



Telephone Number

+



3d

Directory Search Dialing



ENTER LETTER (s)

SA

[100]SALES 3

[005]SALES 2

[001]SALES

5551234

Enter the first letter(s) of the name you wish to search.
Ex: "SA"

(See Note 4)

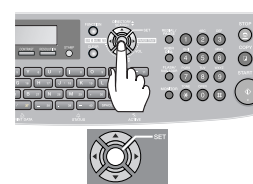

2 →

Select the desired Transmission setting.
(See the column on the right)

- 3a** Quick Name Search Dialing
or
- 3b** One-Touch/ABBR. Dialing
and/or
- 3c** Manual Number Dialing
and/or
- 3d** Directory Search Dialing

4

You can send the same document(s) to multiple stations. Multiple stations can be selected by the Step 3a (3b), 3c and/or 3d, and then pressing **START**.

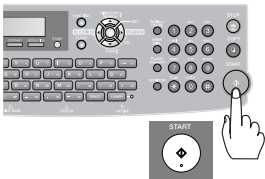

The document(s) is stored into memory with a file number. Then starts sending the document(s).

Transmission Settings

CONTRAST Adjusting the Contrast of scanned image data by pressing cursor keys (◀/▶).

← Lighter Normal Darker →

CONTRAST
- [■■■] +

RESOLUTION (See Note 3)

STANDARD for standard originals
FINE for detailed originals
S-FINE for finer detailed originals
600 dpi for 600 dpi detailed originals
HALFTONE (FINE) for photo originals with Fine Resolution
HALFTONE (S-FINE) for photo originals with S-Fine Resolution
HALFTONE (600 dpi) for photo originals with 600 dpi Resolution

STAMP Verification Stamp
 ON : The light is lit.
 OFF : The light is off.

Dialing No. Indication Sample

When Fax Parameter No. 119 is set to "1:One-Touch". (See page 112.)

<ABBR No.>

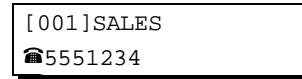

<One-Touch>

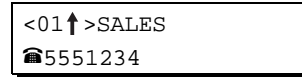

↑:Upper Side
↓:Lower Side

When Fax Parameter No. 119 is set to "2:Quick Name Search". (See page 112.)

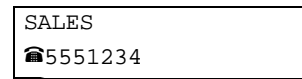

NOTE

1. If your machine sounds an alarm (pi-pi-pi) in Step 3 above, this indicates that the Dialer is Full (More than 50 transmission job reservations have been already reserved).
2. Auto Dialer (Address Book/One-Touch/ABBR.) is only available when stations are registered. (See page 96, 98)
3. When transmitting at S-Fine or 600 dpi, there is a possibility that printing quality may deteriorate at the remote station due to its reception capability. If this occurs, re-send with Direct Transmission or use "Fine" Resolution.
4. You can search for another name starting with the same character by scrolling with the Cursor Keys (▼/▲).



Getting To Know Your Machine

Operation Chart

■ To Stop the Transmission

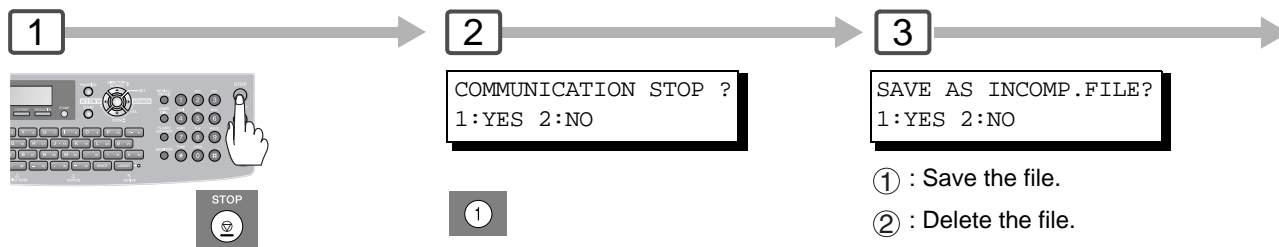

NOTE: To select the Comm. Journal printout condition, change the setting of Fax Parameter No. 12. (See page 110)

- If FAX Parameter No. 31 (**Incomplete File Save**) is set to "Valid" (See Page 111).
- To retry an Incomplete File, see page 82.

■ Making Copies

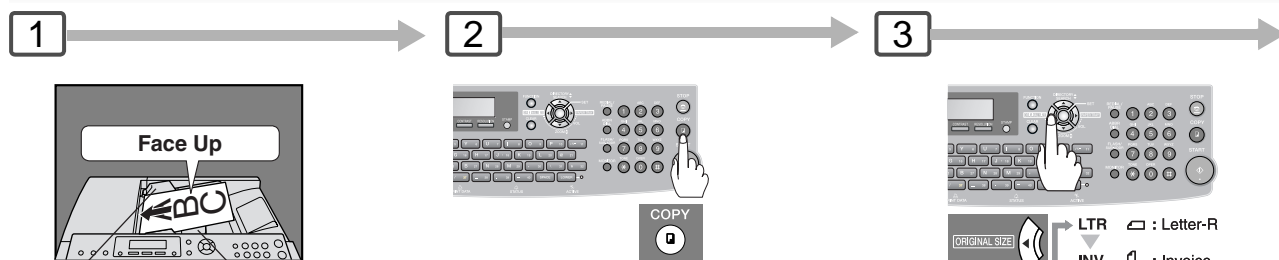

Original Guides* Max. 100 pages (Letter size originals)
Adjust to the original's width.

*Hold the center of the guides when adjusting the width.

Original Size: Invoice - Legal

NOTE:

1. The default original size is "LETTER". If you use the Multi-Size Feeding function, change the default original size to "MIX" in the Copier Settings (For Key Operator), Parameter No. 13 (ORIGINAL SIZE). (See page 117)
2. This function is available only when the optional Tray-2 is installed and both Legal and Letter-R size papers are loaded in Tray-1 and Tray-2 respectively.

- Original Size
- LTR ☐ : Letter-R
 - INV ☐ : Invoice
 - INV ☐ : Invoice-R
 - LGL ☐ : Legal
 - MIX ☐ : Letter and Legal

■ Using the ADF

Originals that cannot be used

- Post Cards, Drawing Papers, Transparencies, Labelling Papers, Heavyweight Papers, Thin Art Papers, Film, Thermal papers

Inappropriate Originals

- Paper with a smooth surface such as glossy and coated papers
- Originals with a Lead Edge that is ripped, creased, folded, punched, or glued
- Mix-sized Originals (except a combination of Legal and Letter)
- Post-it Notes
- Pressure sensitive or carbon backed papers
- Paper with excessive curl
- Stapled originals
- Freshly printed copies from a laser printer
- Originals with fresh White-Out (Liquid paper correction fluid)

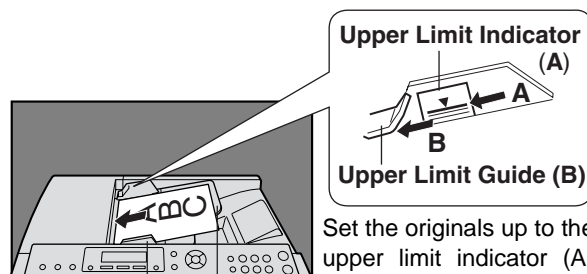

ADF Tray
Original Guides
Adjust to the original's width.

NOTE:

You must not try to send/scan an original shorter than 4.7 inches (120 mm).



4
PRINT COMM. JOURNAL?
1: YES 2: NO

5
Stop the transmission.

1 Print Communication
Journal
(COMM.JOURNAL)



Copy Ratio
(See page 88)



Number of
Copies
(Max. 999)

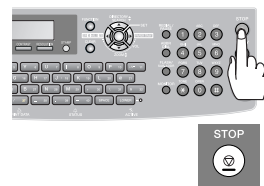

STOP to return to
standby.

NOTE:
When the desired copy size
paper is not loaded in the
paper tray(s), use the Sheet
Bypass (see page 92).

■ Copying onto Transparency Film (OHP), Thick (Heavy) Paper Stock, etc. (except Thin paper)

Before Pressing the Start Key

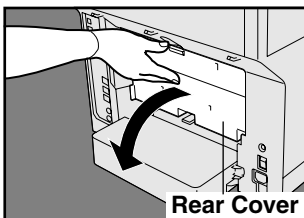

Making Copies

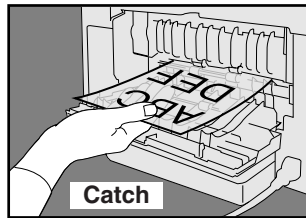

- ① Open the Rear Cover.
- ② Catch the ejected copy (do not pull).
- ③ Close the Rear Cover.

NOTE:
Do not open the Rear Cover when copying
Thin paper as it may cause a paper jam.



Getting To Know Your Machine

Operation Chart

■ Adding Paper (Paper Trays: Tray-1 and Tray-2)

1

For Tray-1

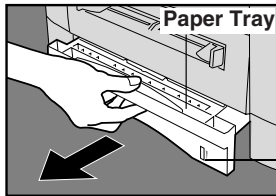

For Tray-2 (Option)

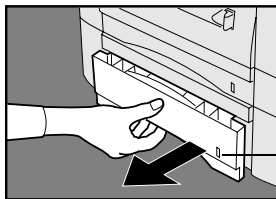

The Paper Level Indicator (Orange) moves down as paper level declines, warning you that the paper is running out.

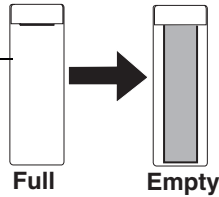

NOTE: When "ADD PAPER" message appears on the display, either Tray-1 or Tray-2 has run out of paper or is not closed firmly (See page 33). Replenish the paper in the tray(s) or ensure that the tray(s) are closed.

2

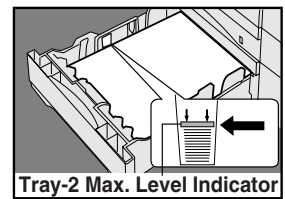
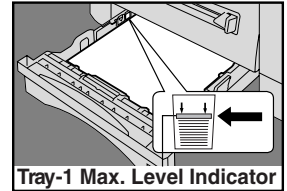

■ Adding Paper (Sheet Bypass)

Copying on Special Paper, etc.

1

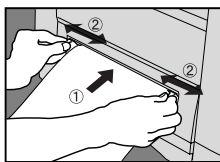

- ① Feed 1 sheet of paper at a time.
Paper Weight: 16 – 44 lb
- ② Adjust the width guides.
Incorrect adjustment may cause the paper to wrinkle, misfed or skew.

NOTE: For envelope printing details refer to the DMS Operating Instructions manual included on the CD.

2

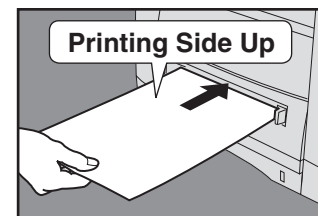

Do not press Start until the LCD display indicates "Paper Size" plus an "*" Press the "*" key to select another size. (See page 92).

3

For Tray-1

Load Paper : Printing Side Down

Paper Weight

1-Sided Copy : 16 – 28 lb

2-Sided Copy : 20 – 24 lb

Paper Capacity : 250 Sheets (20 lb)

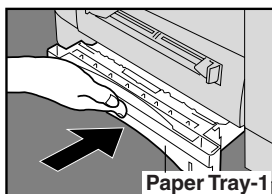

Paper Tray-1

For Tray-2

Load Paper : Printing Side Down

Paper Weight

1-Sided Copy : 16 – 28 lb

2-Sided Copy : 20 – 24 lb

Paper Capacity : 550 Sheets (20 lb)

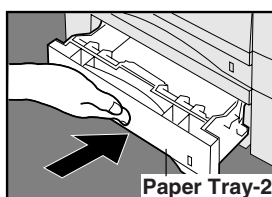

Paper Tray-2

Firmly close the Paper Tray.**NOTE:**

1. To prevent paper jams or other problems, adjust the paper guides (Length & Width) when adding paper into the tray.
2. When changing the paper size, See page 118.
3. Make sure that the paper is set properly and that it does not exceed the Tray-1/Tray-2 Max. Level Indicator.

■ Problem Solving

NOTE:

- 1) Feeding paper into the Sheet Bypass at the same time when the copying/printing has started and paper is feeding from either Tray 1 or Tray 2, will show "REMOVE MISFED PAPER J00" message on the LCD display. When this occurs, remove the paper from the Sheet Bypass to reset the jam indication then resume copying/printing.
- 2) Do not leave a paper in the Sheet Bypass as paper jam indication may display.

**Adding Paper****Replacing Toner Container** (See page 28)**Removing a Misfed Paper** (See page 30)**U## (User Error Code)** (See page 32)**J## (Jam Error Code)** (See page 32)**E## (Machine Error Code)**

(Call your authorized dealer)

Maximum Copies Limitation (See page 33)



Getting To Know Your Machine

Operation Chart

■ Problem Solving

■ Replacing Toner Container

Low Toner message will follow this progression:
(Order the Toner Container using the Order Form (See Note below).
Replace the Toner Container before the Toner runs out)

TONER IS RUNNING LOW
U13

Toner is Low*.
Machine can make less than 500 prints**.

WARNING!! TONER LOW
LESS THAN 50 PAGES

Toner is Nearly Empty.
Machine can make less than 50 prints*.

OUT OF TONER
U13

Toner is Empty.
Machine stops.

* Shake the toner container well, or this message may display.
** Based on 5% print coverage.
(See page 12)

NOTE:

When ordering the Toner Container, print the Order Form using the following procedures, and Fax it to your Authorized dealer.

Press **FUNCTION** on the Panel.

FUNCTION (1-9)
ENTER NO. OR ∨ ^

Press **7** **8** **SET** **3**.

3:TONER ORDER FORM?
PRESS SET TO PRINT

Press **SET** to print the Order Form.

(Operate with the Power Switch in "ON" position)

1

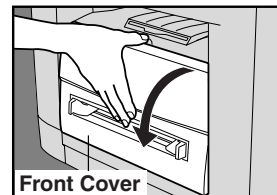

Front Cover

5

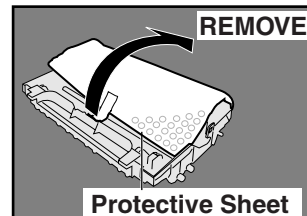

Protective Sheet

CAUTION

Be careful not to scratch the surface of the OPC Drum (Green), and not to touch it with bare hands. The OPC Drum is sensitive to light.

To prevent optical exposure problems, do not expose the OPC Drum to direct sunlight or bright light.

9

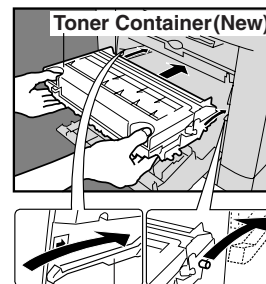

Guide Rails

Place the Toner Container over the Guide Rails and insert it until it stops.

If "2:NO" is selected in Step 12 on page 29:

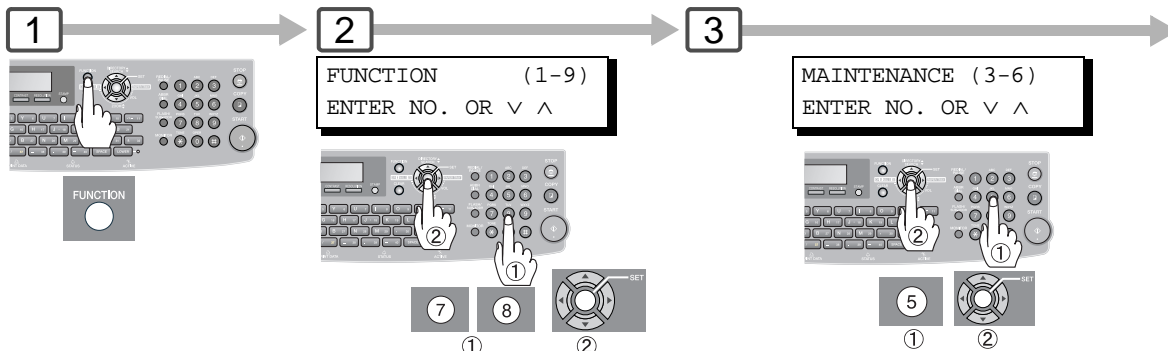

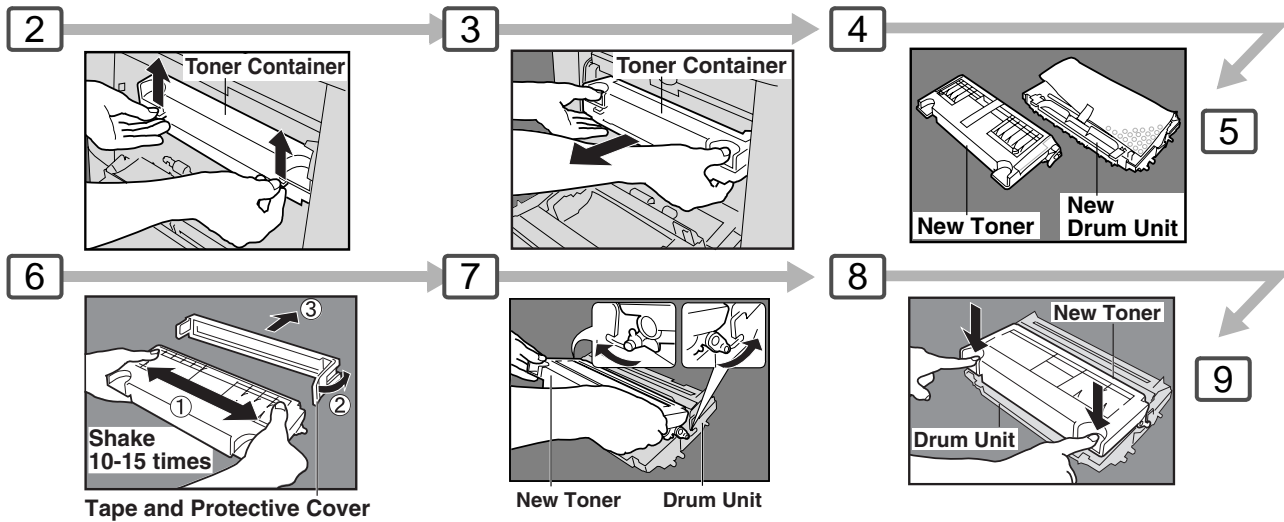

ATTENTION

- Shake the toner container well, as toner may accumulate on one side during transportation.
- For optimum print quality, use the genuine Toner Container. Store Toner Container in a cool dark place. Do not remove the protective cover until you are ready to use it.

NOTE:

Return the replaced Toner Container to your Authorized dealer.

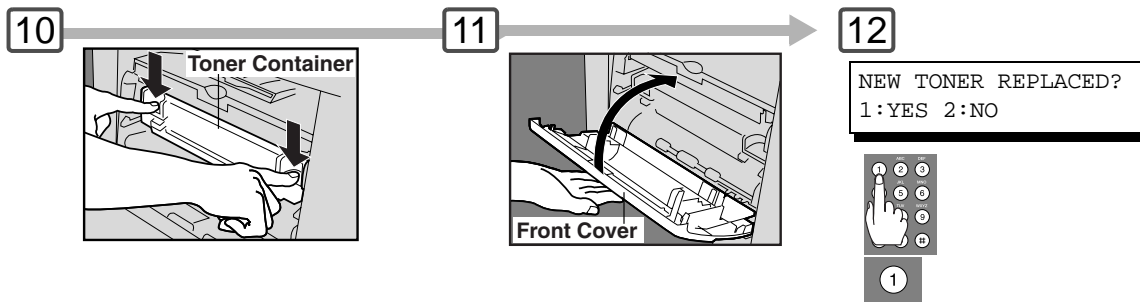

4

3: TONER REPLACEMENT?
1: YES 2: NO

NOTE:

1. If "2:NO" is selected, the image density may be inadequate and may cause Copy/Print quality issues.
2. This message is not displayed if you change the toner container after the "OUT OF TONER" is displayed.



Getting To Know Your Machine

Operation Chart

■ Problem Solving

■ Removing a Misfed Paper (Paper Feed/Paper Transport/Automatic Duplex Unit Area)



REMOVE MISFED PAPER
J44

J43, J44, J82, J83:

NOTE:

The J## Code indicates the most probable Jam location. If the jam message reappears after the jam is cleared, paper is most likely jammed at other location(s). Check the Jam Error Codes Table on page 32 for other check points and remove all misfed paper.

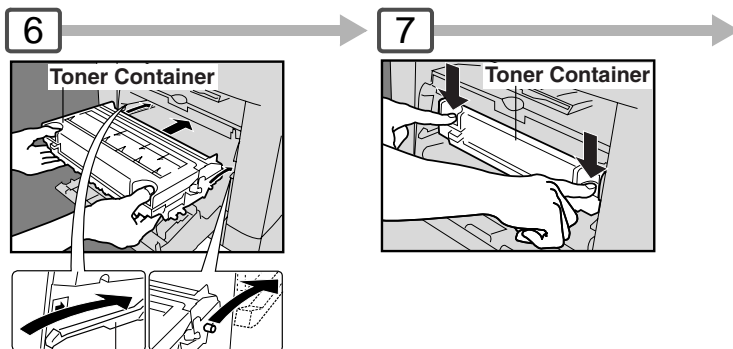
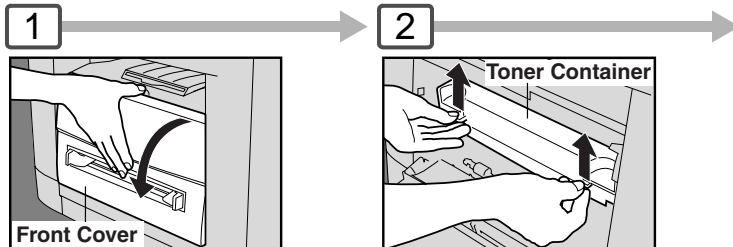
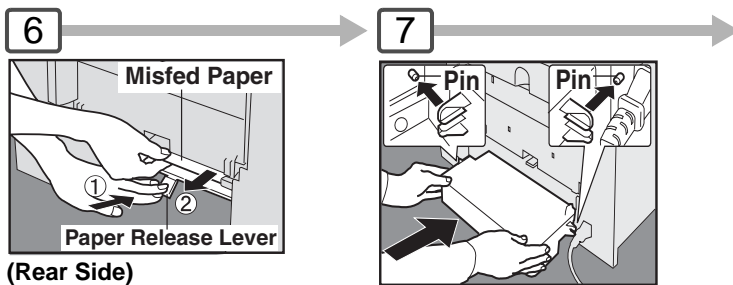
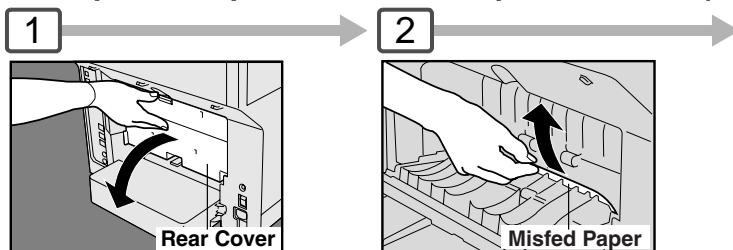

Guide Rail

Place the Toner Container over the Guide Rails and insert it until it stops.

J01, J02, J43, J44, J80:

■ Removing a Misfed Paper (ADF) : J71, J72, J74, J75, J92, J93



Ex: REMOVE MISFED PAPER
J92

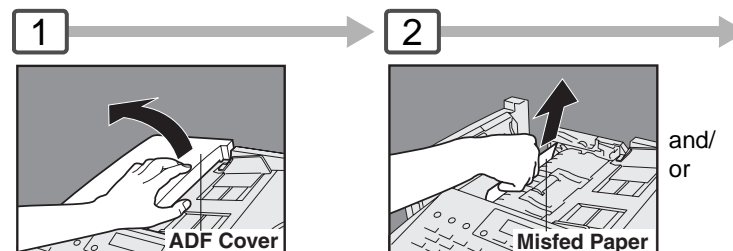

Remove Misfed Paper.

and/
or

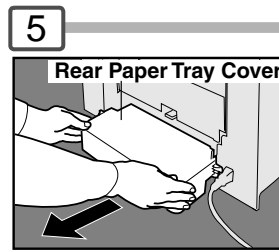
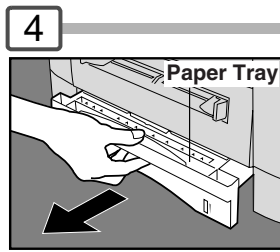
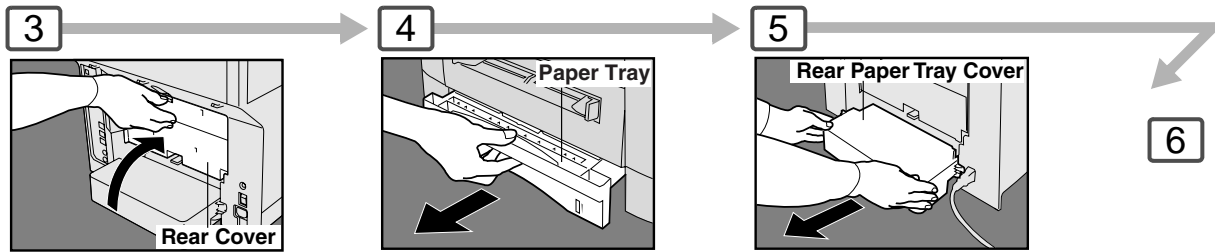

6

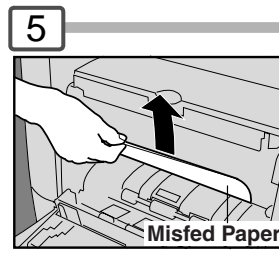
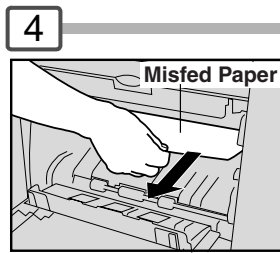
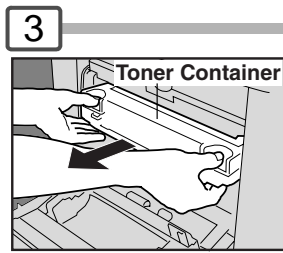
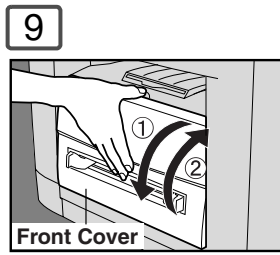
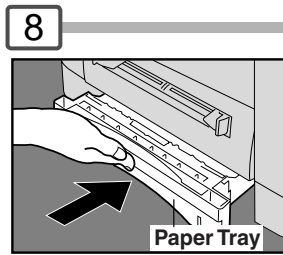

6

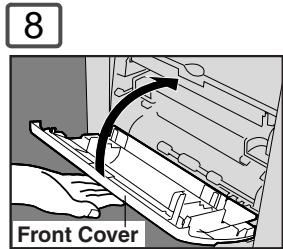

CAUTION

Do not scratch or touch the surface of the OPC Drum (Green) with bare hands. The OPC Drum is sensitive to light. To prevent optical exposure problems, do not expose the OPC Drum to direct sunlight or bright light.

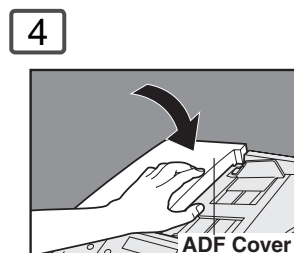
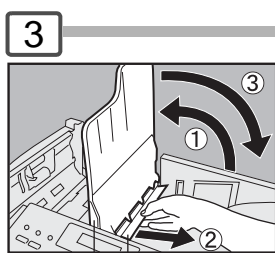

ADF Tray



Getting To Know Your Machine

Operation Chart

■ Problem Solving

■ User Error Codes (U Code)

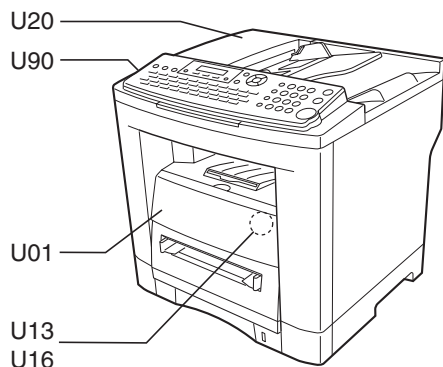

Code	Check Points	Code	Check Points
U01	Front Cover is open.	U20	ADF Cover is open.
U13	Low Toner or Out of Toner. (See page 28)	U90	Battery requires replacement. (See page 137)
U16	Toner Container is not installed correctly.		

■ Jam Error Codes (J Code)

Code	Check Points	Code	Check Points
J00	Remove paper from the Sheet Bypass.	J71, J72, J74, J75, J92, J93	Remove misfed paper(s) in the ADF. (See page 30)
J01, J02	Pull out the paper tray(s) and remove the jammed paper from the tray(s). Check to make sure the Paper Guides are properly adjusted in the tray(s). (See page 30)		
J43, J44, J80, J82, J83	Remove misfed paper(s) inside the machine. (See page 30)		

NOTE

1. The J## Code indicates the most probable Jam location. If the jam message reappear after the jam is cleared, paper is most likely jammed at other location(s). Check the Jam Error Codes Table above for other check points and remove all misfed paper.
2. Make sure that the Jam Error Code disappears after removing the misfed paper.
3. The Jam Error Code will not disappear if the paper is still jammed in the machine. Check again and remove all misfed paper.

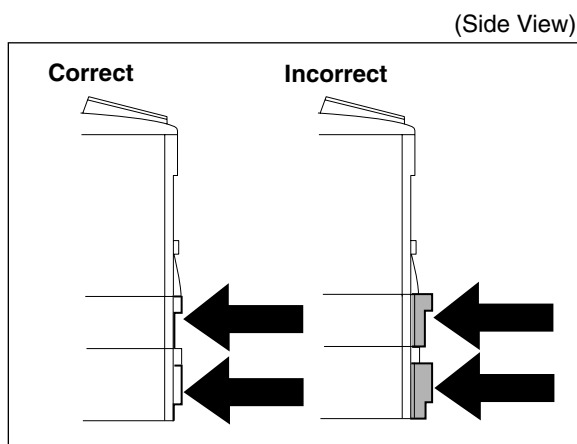
ATTENTION

When the optional Paper Tray-2 is installed, and either Paper Tray (Tray-1 or Tray-2) is not closed firmly, paper jam may occur.

NOTE: When the optional Tray-2 is installed and the same size of paper is loaded in both trays, the paper will be supplied from Paper Tray-2 first. This is the default setting, if you wish to change the setting, please consult with your authorized dealer.

To make copies from the Sheet Bypass

1. Set the original(s) on the ADF.
2. Press .
3. Set a sheet of paper into the Sheet Bypass.
4. **PRESS "j"** appears in the upper line of the LCD display.
5. If you wish to make multiple copies from the Sheet Bypass (Thick media), input the desired number of copies first and press . After each media sheet is processed, a **"BYPASS ADD PAPER"** prompt message will appear on LCD display, insert an additional media into the Sheet Bypass (one-at-the-time) until your copy job is completed.

Adding Paper / Tray-2

Always remove all paper from Tray-2, fan and straighten remaining paper before replenishing paper. This helps prevent multiple sheets of paper from feeding through the Tray-2 at one time, thus reducing paper jams.

Maximum Copies Limitation



After setting the maximum allowed number of copies for each department (See page 117), consult with your Key Operator when the total copy count reaches the designated limit and the "DEPT. MAXIMUM COPIES HAS BEEN REACHED" message appears on the LCD.



Getting To Know Your Machine

Mode Setting

■ Using the Functions

The following functions can be started by first pressing **FUNCTION** and then entering the function number, or by pressing  or  scroll key repeatedly until the desired function appears on the LCD display.

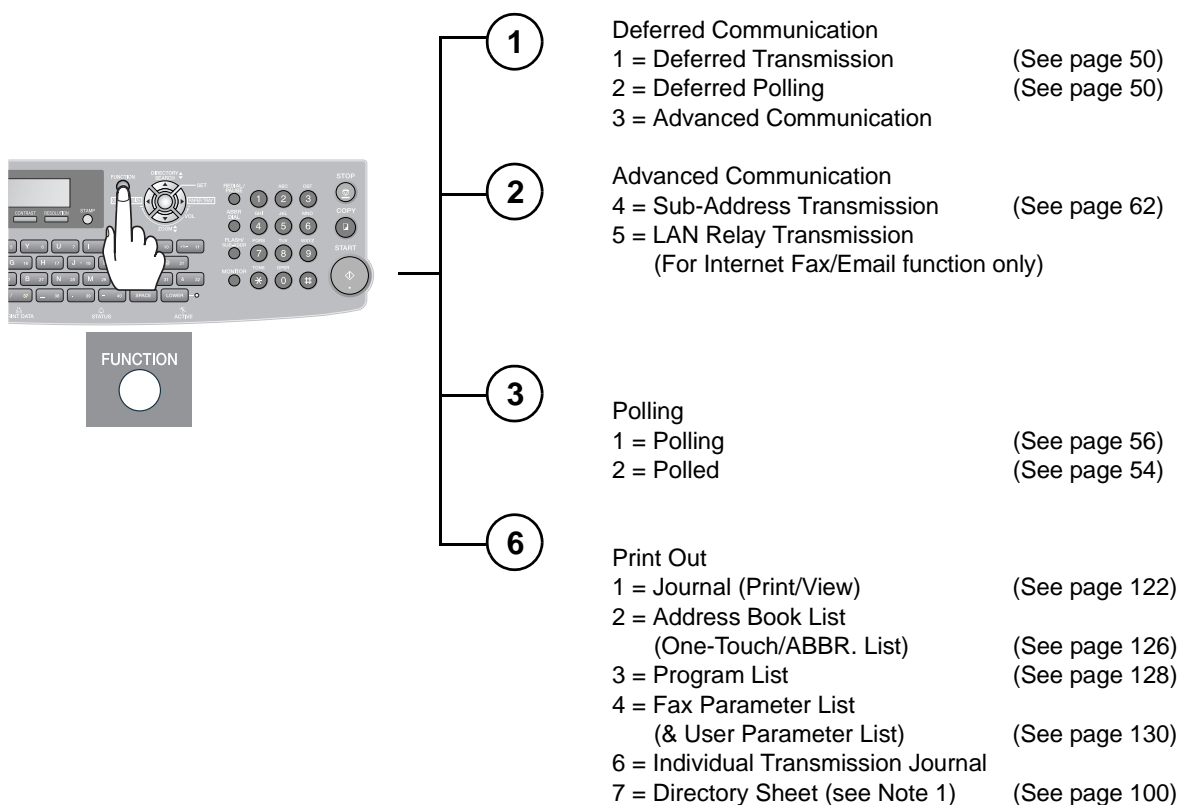

NOTE

1. Available when Fax Parameter No.119 is set to "1:One-Touch". (See page 112)
2. The Select Mode (**FUNCTION** ) settings can be temporarily changed for the current communication. Upon its completion, however, these parameters are returned to their preset default values (Home position). You can change the Home position of these settings in the Fax Parameters mode. (See page 108)

- 7** Set Mode
- 1 = User Parameters (See page 106)
 - Date & Time
 - Logo
 - Character ID
 - ID Number (Fax Telephone Number)
 - 2 = Address Book (See page 96)
 - (One-Touch/Abbreviated Numbers) (see Note 1)
 - 3 = Program Keys (See page 58)
 - 4 = Fax Parameters (See page 108)
 - 8 = Maintenance = Toner Order Form/Toner Replacement/ (See page 28)
 - LCD Brightness (see Note 3)
- 8** Select Mode (see Note 2)
- 1 = Communication Journal = OFF/ON/INC (See page 124)
 - 2* = Delivery Notice = OFF/ON*
 - 3 = Cover Sheet = OFF/ON (See page 64)
 - 5 = RCV to Memory = OFF/ON/PRINT
 - 6* = File Type and Name = TIFF/PDF*
 - 9 = Memory Transmission = OFF/ON (See page 38, 42)
- (*:2 and 6 for Internet Fax/Email function only)
- 9** Edit File Mode
- 1 = File List (Print/View) (See page 76)
 - 2 = Change Start Time/Station (See page 78)
 - 3 = Delete File (See page 78)
 - 4 = Print File (See page 80)
 - 5 = Add Document (See page 80)
 - 6 = Retry Incomplete File (See page 82)

NOTE

3. To adjust the character brightness of the LCD display, press **FUNCTION** **7** **8** **SET**, **6** **SET**, and then press **◀** or **▶** until the desired brightness is achieved.



Getting To Know Your Machine

Control Panel

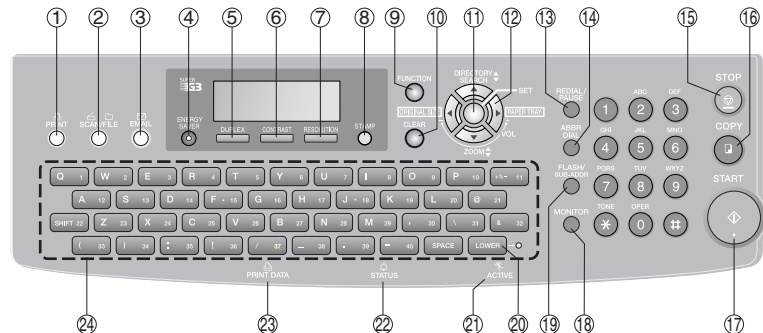

No.	Icon	Contents	No.	Icon	Contents
1		PRINT Key Used for Printer function.	2		SCAN/FILE Key Used for optional Network Scanner Function. (Available if the optional Internet Fax/Email/Network Scanner Module (IF-47) is installed.)
3		EMAIL Key Used to select the EMAIL mode. (Available if the optional Internet Fax/Email/Network Scanner Module (IF-47) is installed.)	4		ENERGY SAVER Key Used to switch the machine into energy saving.
5		DUPLEX Key Used to scan the document(s) on both faces.	6		CONTRAST Key To adjust the Exposure manually. (See page 23)
7		RESOLUTION Key Used to set Standard, Fine, Super-Fine, 600 dpi or Halftone (Fine, Super Fine, 600dpi). (See page 23)	8		STAMP Key Used to turn the verification stamp ON or OFF. Lights when the verification stamp is set to ON. (See page 111, Fax Parameter No. 028)
9		FUNCTION Key Used to start or select the function and subfunctions. These functions are explained in detail on page 34.	10		CLEAR Key Clears the number or character on the LCD display. Go back to the previous LCD screen and function as Back Space key.
11		SET Key Used to set operations.			
12		Cursor Keys <ul style="list-style-type: none"> Adjust the Monitor and Ringer volume. Move the cursor while entering numbers and characters. Search the station name for Quick Name Search and Directory Search Dialing. Confirm the entered station for multi-station communication. Select functions. Confirm the current communication modes (e.g. Page number, ID, Dialed Telephone number or Email address, File number) when the machine is ON LINE. To select the zoom (Copy) ratio, etc. Use to select original size, etc.			
		ORIGINAL SIZE Key Used to select the original size manually.			
		PAPER TRAY Key Selects the paper tray.			

No.	Icon	Contents	No.	Icon	Contents
13		REDIAL/PAUSE Key Used to enter a pause when programming or dialing a telephone number, or to redial the last dialed number. (See page 40)	14		ABBR DIAL Key Used to start Abbreviated Dialing. (See page 22)
15		STOP Key Press to abort the current operation and reset selected mode(s) (Email/Copy/Scanner Functions) and return to the Facsimile Function.	16		COPY Key Used for Copy function.
17		START Key Press this key to start activation.	18		MONITOR Key Used to start On-Hook Dialing.
19		FLASH/SUB-ADDR Key Used to enter the Sub-Address or to access some features of your PBX.	20		LOWER Key Used to switch either upper or lower row of the One-Touch Key. (See page 98)
21		ACTIVE LED (GREEN) Flashes: When machine is active. Lights: When the received fax message is in memory.	22		STATUS LED (RED) Lights/Flashes when trouble occurs. Lights: Machine detected a trouble status <ul style="list-style-type: none"> No paper in the selected tray or toner has run out. Machine detected trouble, such as paper misfed or jammed. Flashes: Machine detected an alarm status <ul style="list-style-type: none"> No paper in the Tray. (Tray not selected) Toner is getting low, etc.
23		PRINT DATA LED (GREEN) Flashes: When receiving printing data. Lights: While printing.			
24		QWERTY Keyboard (Character Keyboard) <ul style="list-style-type: none"> Used to input the Characters. Used for One-Touch Keys. Used to enter a symbol for the LOGO, Character ID, Station Name and for the Email address. Use or to select the desired symbol(s). 			

LCD Display (Copy Function)

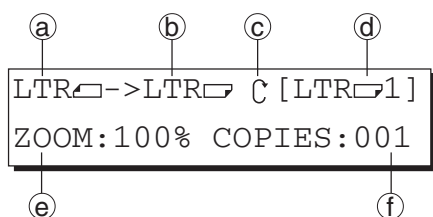

- a Original Size
- b Copy Size
Select the zoom (Copy) ratio with the Cursor Keys (/ .
- c Scanned data will be rotated.
- d Paper Size in Paper Tray
("PRESS*" indicates Sheet Bypass is to be used.)
- e Zoom Ratio
- f Number of Copies



Facsimile Features

Sending Documents

General Description

Your machine quickly stores the document(s) into the machine's memory. Then, starts to dial the telephone number. If the transmission fails, your machine will retransmit the remaining unsuccessful page(s) automatically.

Memory Transmissions

1

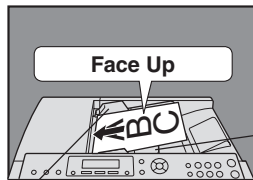

*Hold the center of the guides when adjusting the width.

Max. 100 pages
(Letter size originals)

ENTER STATION(S)
THEN PRESS START 00%

Make sure that the above message is shown on the display. If not, press the STOP key.

Original Guides*

3a

Quick Name Search Dialing (see Note 2)
(When Fax Parameter No. 119 is set to "2:Quick Name Search", See page 112.)



Enter the first letter of the name you wish to search repeatedly until it is shown on the LCD display.search.
Ex: "S"

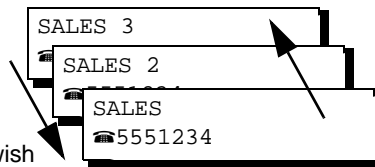

(See Note 5)



3b

One-Touch/ABBR. Dialing (see Note 2)
(When Fax Parameter No. 119 is set to "1:One-Touch", See page 112.)



(See page 40)

or



ABBR DIAL + ABBR No.(3-digit)

3c

Manual Number Dialing (Up to 50 Stations)



Telephone Number

+



3d

Directory Search Dialing

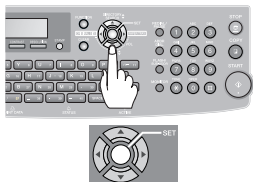

Enter the first letter(s) of the name you wish to search.
Ex: "SA"

ENTER LETTER (s)
SA

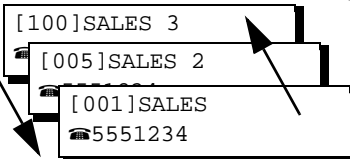

See Note 5

NOTE

1. If you need to dial a prefix to get an outside line, dial it first then press **PAUSE** to enter a pause (represented by a "-") before dialing the full number.

Ex: 9 **PAUSE** 5551234

Or use "Dial Prefix" function to automatically add the prefix (see page 86).

2. Auto Dialer (Address Book/One-Touch/ABBR.) is only available when stations are registered. (See page 96, 98)

- 2** → Select the desired Transmission setting. (See page 23)
- 3a** Quick Name Search Dialing
or
3b One-Touch/ABBR. Dialing
and/or
3c Manual Number Dialing
and/or
3d Directory Search Dialing

- 4** You can send the same document(s) to multiple stations. Multiple stations can be selected by any combination of the Steps 3a (3b), 3c and/or 3d, and then pressing **START**.

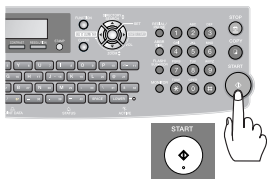

The document(s) is stored into memory with a file number. Then starts sending the document(s).

- If memory overflow occurs while storing originals, the machine will stop and the remaining originals will remain on the ADF. In the factory default setting (Fax Parameter No. 82 (Quick Memory XMT)) is set to **"Valid"**, the machine will transmit the stored documents automatically when transmitting to one station. If Fax Parameter No. 82 is set to **"Invalid"** and transmitting to one station, the machine will change the transmission mode from Memory to Direct XMT automatically when it detects that memory overflow will occur. If set to **"Valid"** and transmitting to multiple stations, the machine will show **"MEMORY FULL"** and prompts you whether to transmit the successfully stored documents or to cancel the transmission.
Press **1** **"YES"** to cancel or press **2** **"NO"** to transmit. If no action is taken within 10 seconds, the machine will start transmitting the stored documents. If memory overflows while storing 1st page, use Direct Transmission.
- An Information Code will be displayed after the transmission has failed or there was no answer at the receiving side after the last automatic redial. The document stored for the transmission will be erased from the memory automatically and the information code is printed for the transmission on the Communication Journal (COMM. JOURNAL).
If you need to retain the incomplete documents even after the last redial, change the Fax Parameter No. 31 (**INC. FILE SAVE**) to **"Valid"** in advance. (See page 111)
To retry the incomplete documents, refer to page 82.

■ To Stop the Transmission

- 1** → **2** → **3** → **4**
- 1** Remove the document(s) from the ADF.
- 2**
- 3** COMMUNICATION STOP?
1: YES 2: NO
1
- 4** PRINT COMM. JOURNAL?
1: YES 2: NO
1 Print Communication Journal and stop the transmission.
2 Stop the transmission.

NOTE

3. If you are using Pulse dialing and you wish to change to Tone dialing in the middle of dialing, press **TONE** (represented by a "/").
The dialing mode will be changed from Pulse to Tone after dialing the digit "/".
Ex: 9 **PAUSE** **TONE** 5551234
4. When transmitting at S-Fine or 600 dpi, there is a possibility that printing quality may deteriorate at the remote station due to its reception capability. If this occurs, re-send with Direct Transmission or use "Fine" Resolution.
5. You can search for another name starting with the same character by scrolling with the Cursor Keys (**▼**/**▲**).



Facsimile Features

Sending Documents

■ Using One-Touch Dialing

(When Fax Parameter No.119 is set to "1:One-Touch", see page 112.)
One-Touch Dialing can be used when the Telephone Number(s) are registered in the One-Touch Keys up to 80 stations (2 stations with each One-Touch Key, 1 - 40).

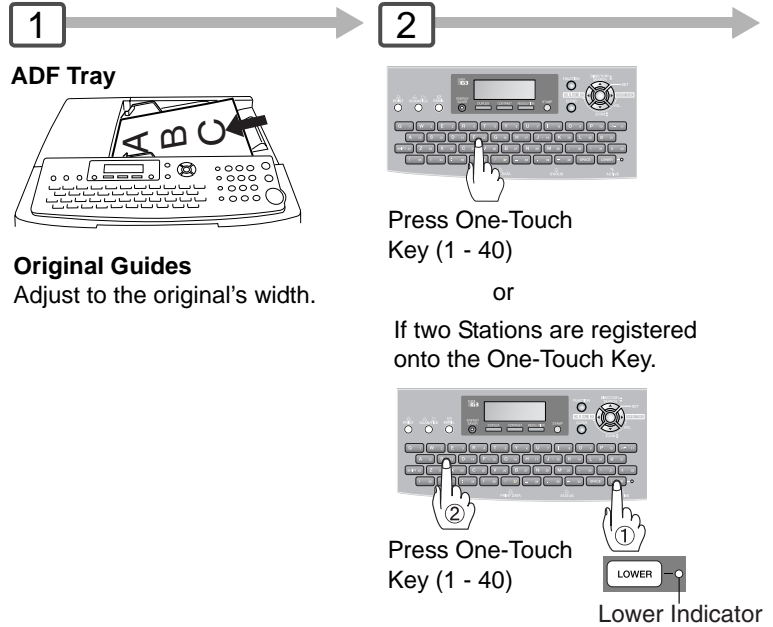

■ Redialing the Last Dialed Numbers

Last dialed numbers (max. 5 numbers) will be recorded and can be used for redialing.

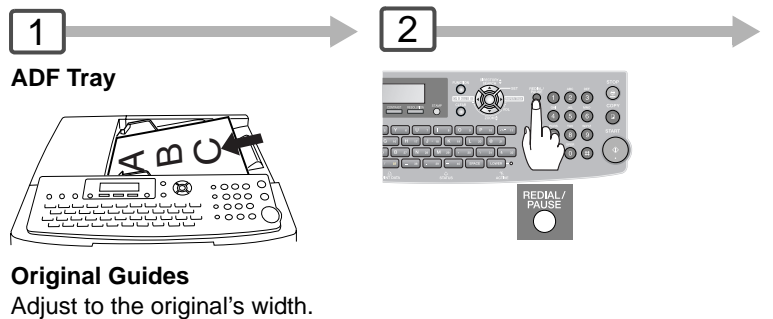

3

Lower Indicator is OFF.

<13↑> SALES 01
☎0123456789001

Lower Indicator is lit.

<13↓> SALES 02
☎0123456789012

When selecting other station(s), repeat Step 2.

4



The document(s) is stored into memory with a file number. Then starts sending the document(s).

3



Select the number
(▼/▲)

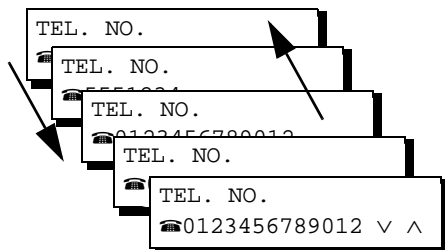

4



The document(s) is stored into memory with a file number. Then starts sending the document(s).



Facsimile Features

Sending Documents

Direct Transmission Reservation (Priority Transmission Reservation)

If you are in a rush to send an urgent document, however there are many files in the memory, use Direct Transmission Reservation to send. The urgent document(s) will be sent immediately after the current communication is finished.

If your machine's memory is full, use Direct Transmission.

Note: You cannot send document(s) to multiple stations in this case.

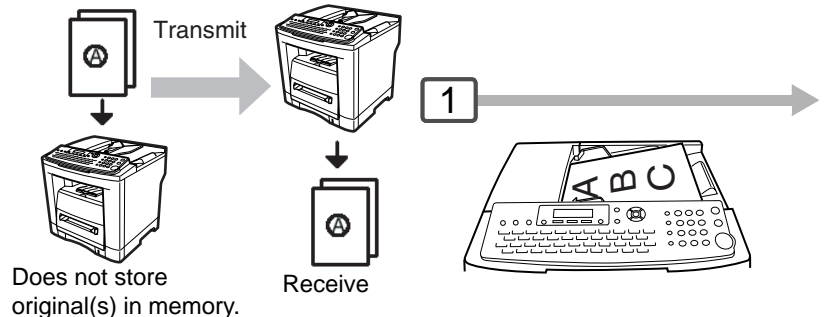

5a Quick Name Search Dialing (see Note 2) (When Fax Parameter No. 119 is set to "2:Quick Name Search", See page 112.)



Enter the first letter of the name you wish to search repeatedly until it is shown on the LCD display.
Ex: "S"

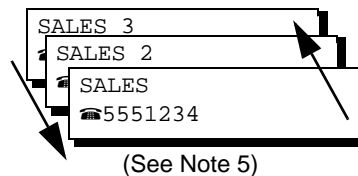

5b One-Touch/ABBR. Dialing (see Note 2) (When Fax Parameter No. 119 is set to "1:One-Touch", See page 112.)

Not necessary to press START Key in Step 6.



When the Telephone Number(s) are registered in the One-Touch/Abbreviated Dialing.

or



ABBR DIAL + ABBR No. (3-digit)

5c Manual Number Dialing



Telephone Number
(Up to 36 digits)

5d Directory Search Dialing (see Note 2)



Enter a letter(s) of a name you wish to search.
Ex: "SA"

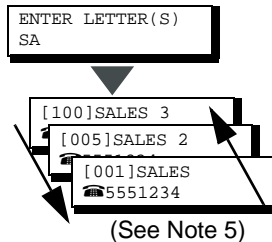

NOTE

1. If you need to dial a prefix to get an outside line, dial it first then press **PAUSE** to enter a pause (represented by a "-") before dialing the full number.
Ex: 9 **PAUSE** 5551234
Or use "Dial Prefix" function to automatically add the prefix (see page 86).
2. Auto Dialer (Address Book/One-Touch/ABBR.) is only available when stations are registered. (See page 96)
3. To stop the transmission, See page 39.

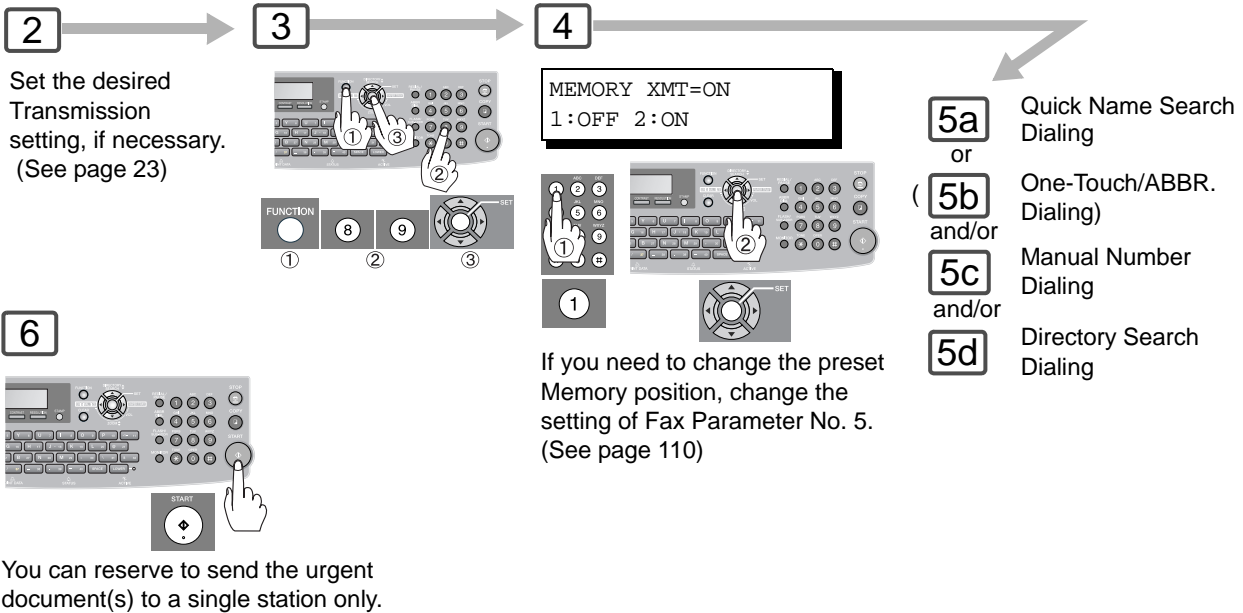

■ Canceling the Direct Transmission Reservation

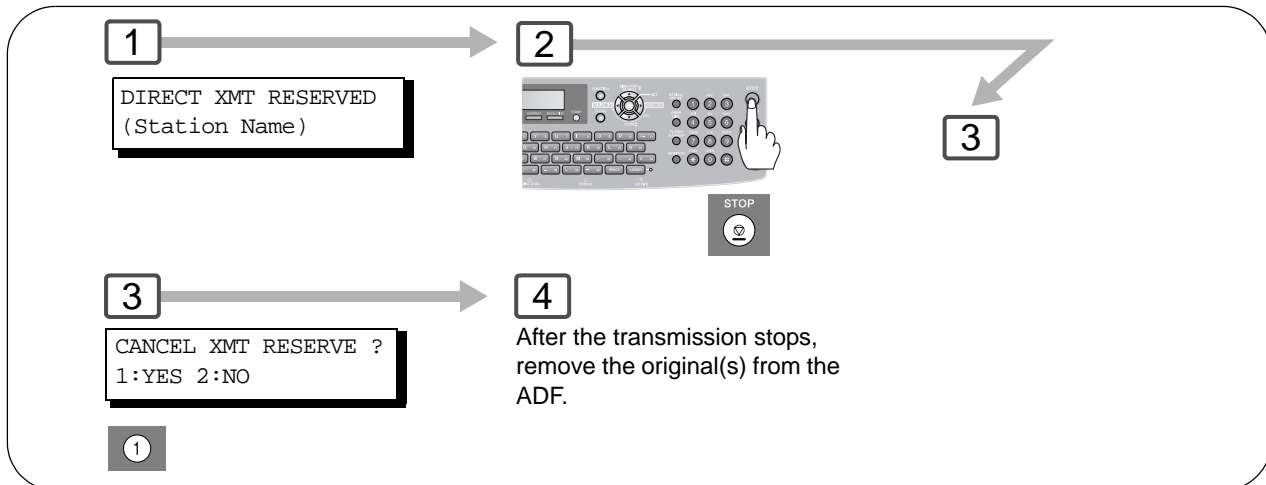

NOTE

- If you are using Pulse dialing and you wish to change to Tone dialing in the middle of dialing, press **TONE** (represented by a "/"). The dialing mode will be changed from Pulse to Tone after dialing the digit "/".
Ex: 9 **PAUSE** **TONE** 5551234
- You can search for another name starting with the same character by scrolling with the Cursor Keys (**▼**/**▲**).



Facsimile Features

Sending Documents

■ Duplex Sending

2-Sided originals can be sent as page orders.

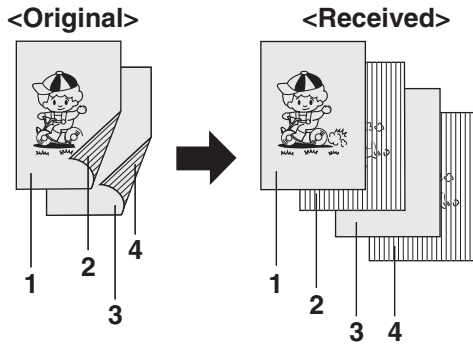

1

ADF Tray



2

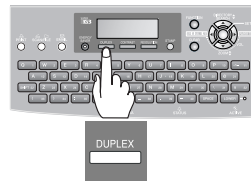

6

INSERT SECOND SIDE
ORIENTATION AS IS

Place the second side of the original(s) of
Step 1 in the order and direction of ejection.

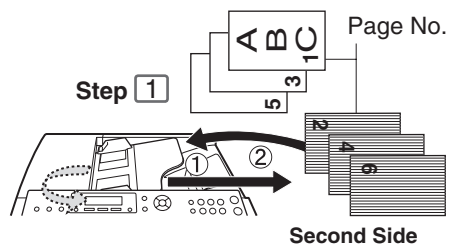

Even Number pages.

Long Edge
Originals

Short Edge
Originals

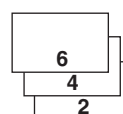
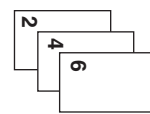



Press ◀ or ▶ to select binding position. (Select within 10 sec.)

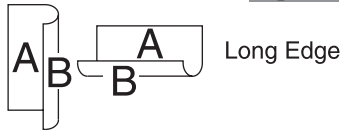

Enter Station(s)

7
PRESS START TO CONTINUE

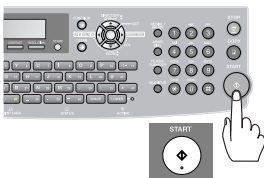

NOTE: If the page count for the Back side does not match the page count for the Front side (i.e. when 2-Sided original(s) are double-fed), "SIDE 1&2 PAGE COUNTS DO NOT MATCH!" and "RESCAN ORIGINALS START WITH 1ST SIDE" will be displayed and all scanned data will be cancelled. If this occurs, restart from Step 1 and Steps 4 to 7.

Real Time and Quick Memory Transmission features are not available.



Facsimile Features

Sending Documents

■ On-Hook Dialing

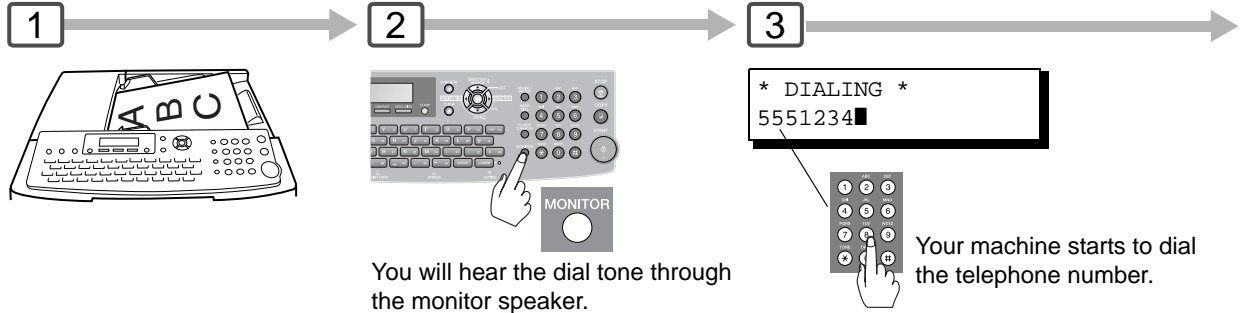

■ Off-Hook Dialing (Voice Mode Transmission)

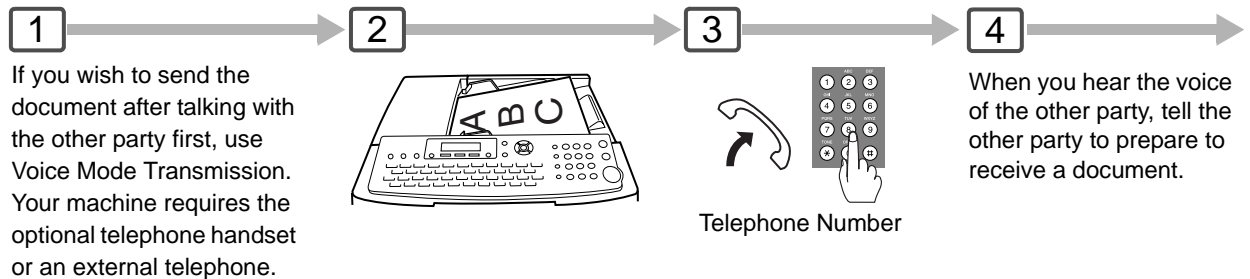

NOTE

1. If you need to dial a prefix to get an outside line, dial it first then press **PAUSE** to enter a pause (represented by a "-") before dialing the full number.

Ex: 9 **PAUSE** 5551234

Or use "Dial Prefix" function to automatically add the prefix (see page 86).

4

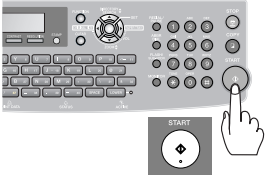

Then when you hear a beep, press

START .

5

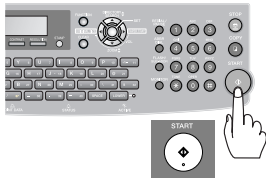

Then when you hear a beep, press **START**
and hang up the handset.

NOTE

- If you are using Pulse dialing and you wish to change to Tone dialing in the middle of dialing, press **TONE** (represented by a "/").
The dialing mode will be changed from Pulse to Tone after dialing the digit "/".
Ex: 9 **PAUSE** **TONE** 5551234
- Off-Hook Dialing is not available with the second telephone line (Line-2).



Facsimile Features

Receiving Documents

Automatic Reception



Documents are received automatically.

Manual Reception

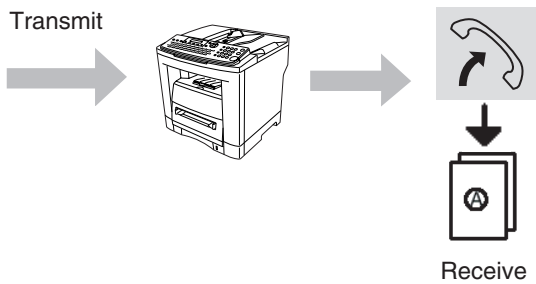

To receive documents manually, change the Fax Parameter No. 17 (**Receive Mode**) to **"Manual"** (See page 110).

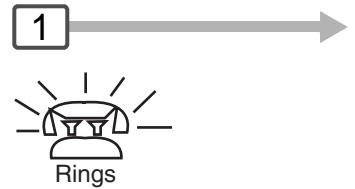

Substitute Memory Reception

If the recording paper runs out, jams or if the toner runs out during reception, the machine automatically starts receiving documents into its image data memory. Stored documents will be printed automatically after replenishing the recording paper, toner or clearing the jam. (See Notes 1, 2 and 3)

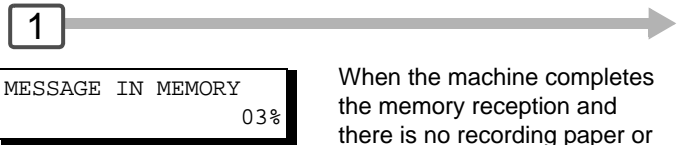

When the machine completes the memory reception and there is no recording paper or toner, this error message appears on the display.

Print Reduction Setting

Transmitted Document

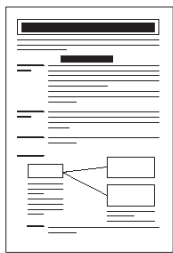

Oversized Document

Received Document

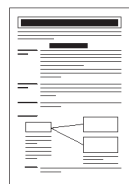

Reduced to fit the loaded paper size (See Note 4)

Automatic Reduction

Based on the document length, your machine will automatically calculate the suitable reduction ratio (70% to 100%). Set Parameter No. 24 (**Print Reduction**) to **"Auto"**. (See page 111)

Fixed Reduction

Pre-determine the reduction ratio from 70% to 100% in 1% increments.

- a) Set Parameter No. 24 (**Print Reduction**) to **"Fixed"**.
- b) Set Parameter No. 25 (**Reduction Ratio**). (See page 111)

NOTE

1. If the memory overflows, the machine will stop receiving and release the communication line. The document(s) stored in the memory up to that moment will be printed out.
2. If you wish to turn off the substitute reception function, change the setting of Fax Parameter No. 22 to **"Invalid"**. (See page 111)
3. The machine cannot print the received documents from the Sheet Bypass.

■ 2-Sided Receiving

Set Fax Parameter No. 95 (DUPLEX PRINT) to Valid. (See Note 5) (See page 112)

Under the following conditions your machine cannot receive 2-Sided transmissions. It will automatically change to a 1-Sided reception.

- When receiving Legal size document(s) with 600 dpi Resolution.
- When the machine detects memory overflow.

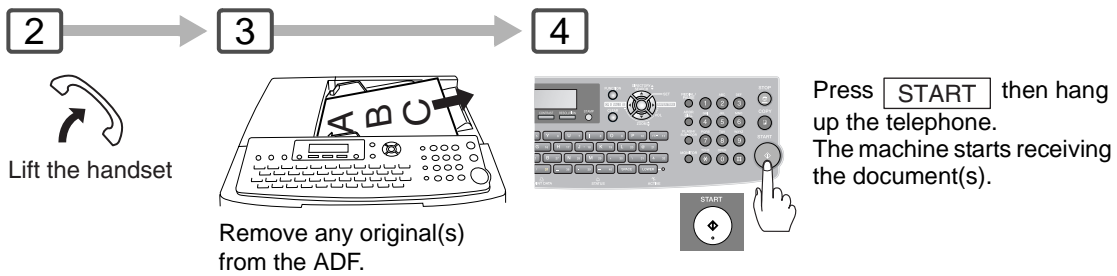

2

Replenish the recording paper, toner or clear the jam.
The document(s) stored in memory will be automatically printed.

Ex: A4 to A4	96%
A4 to Letter	90%
Letter to Letter	96%
Legal to Letter	75%

NOTE

4. If the received document is extremely long (over 39% longer than the recording paper), the document is divided into separate pages. (When printing on separate pages, the bottom 0.5 in (13 mm) of the 1st page's data will overlap on top of the next page.)
5. If the machine detects memory overflow while receiving in the Duplex Print setting, it will switch from duplex printing to single-sided printing.

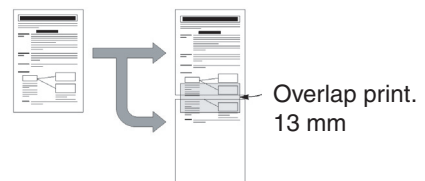



Facsimile Features

Timer Controlled Communications

General Description

You can send document(s) to one or multiple stations at any preset time within the next 24 hours. Up to 50 built-in timers can be set for deferred communication.

Deferred Transmission

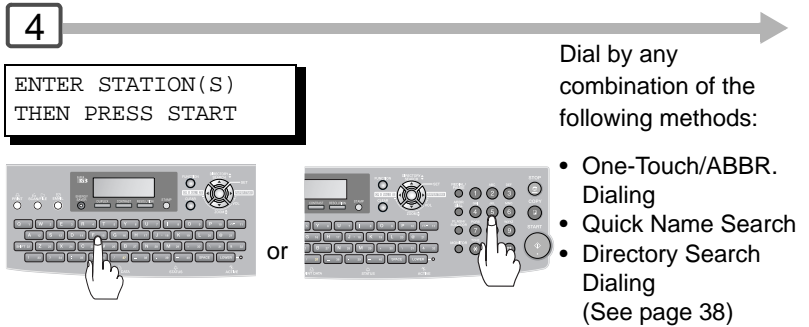
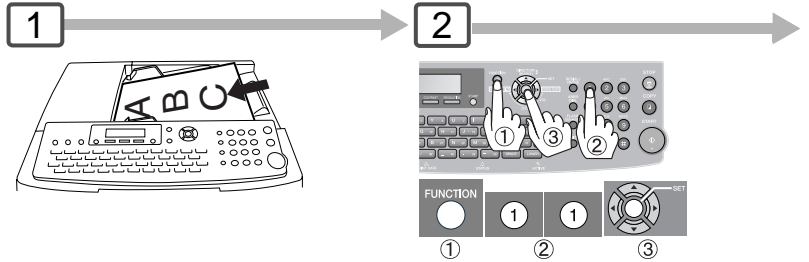
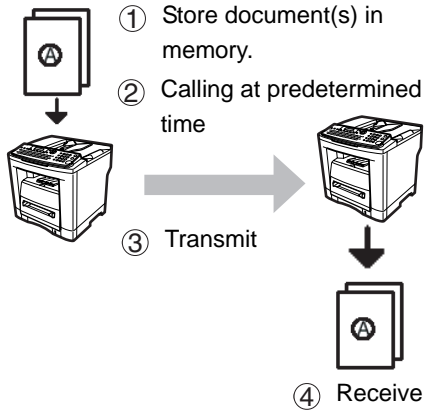

Deferred Polling

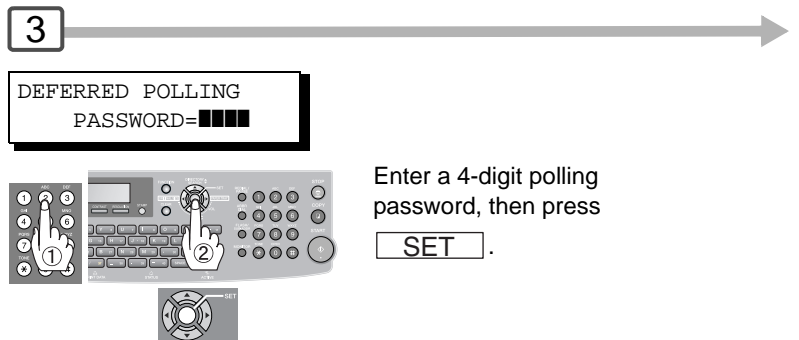
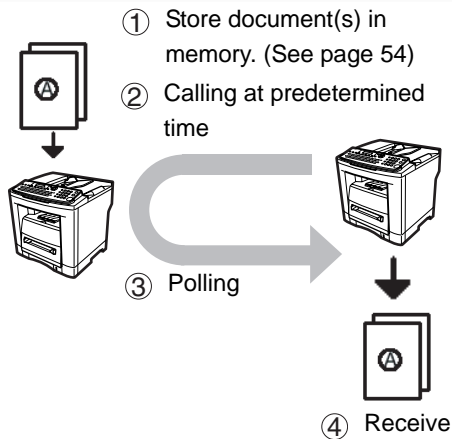

NOTE

1. To change or cancel the Deferred Communication settings, See page 78.

3

DEFERRED XMT
START TIME ■ :

Enter the start time from the keypad, then press **SET** .(use a 4-digit, 24-hour clock)

4

Ex: ②③③① and **SET**



5

(Station name)
☎5551234

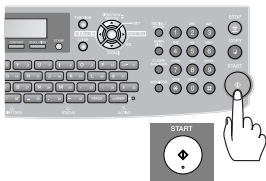

2

DEFERRED POLLING
START TIME ■ :

Enter the start time from the keypad.
(Use a 4-digit, 24-hour clock)

3

Ex: ②③③① and **SET**

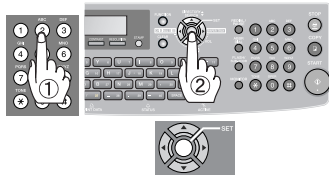

4

ENTER STATION(S)
THEN PRESS START

Dial by any combination of the following methods:

- One-Touch/ABBR. Dialing
- Quick Name Search
- Directory Search Dialing (See page 38)

5

(Station name)
☎5551234

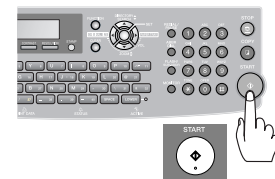

NOTE

2. If you enter a wrong number, press **CLEAR** then reenter the correct number.



Facsimile Features

Batch Transmission

■ General Description

To reduce transmission time and cost, this feature allows your machine to accumulate different documents for the same destination(s) to be transmitted in a single phone call.

■ Real-Time Batch Transmission

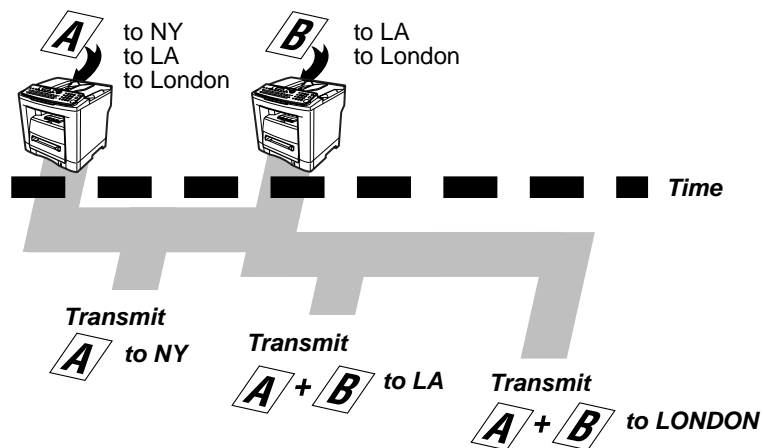

NOTE

1. The machine cannot Batch a file(s) that is/are under "Waiting to Redial" status or is currently being sent, but it will Batch files that have not been dialed.

During memory transmission, this machine searches its memory for reserved files (up to 5 files) to transmit to the same destination, automatically batching and transmitting them in a single phone call.



Facsimile Features

Polling

■ General Description

Polling means calling other station(s) to retrieve document(s). The other station must know in advance that you will call and must have document(s) set on the ADF or stored into the memory. You may need to set a polling password, shared by the other station, to ensure security.

■ Preparing to be Polled

To allow other stations to poll your machine, you must prepare your machine by storing a document into memory. Be sure to set the polling password before storing the document into memory. After being polled, the documents stored in the memory will be erased automatically. To retain the documents in memory so that they can be polled repeatedly change the Fax Parameter No. 27 (**POLLED FILE SAVE**) to "Valid". (See page 111)

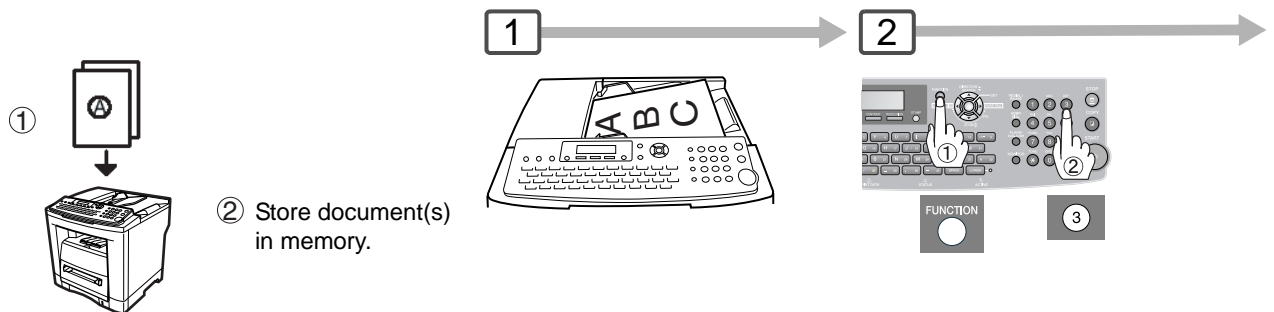

NOTE

1. You can still send or receive documents even when the machine is set to be polled.
2. Only 1 polled file can be stored in memory. If you need to add document(s) into the same polled file, See page 80.
3. To delete a polled file, See page 78.
4. If you have set the polling password in Fax Parameter No. 26, the password will appear on the display. (see page 111)
You can still change the password temporarily by overwriting it with a new one.

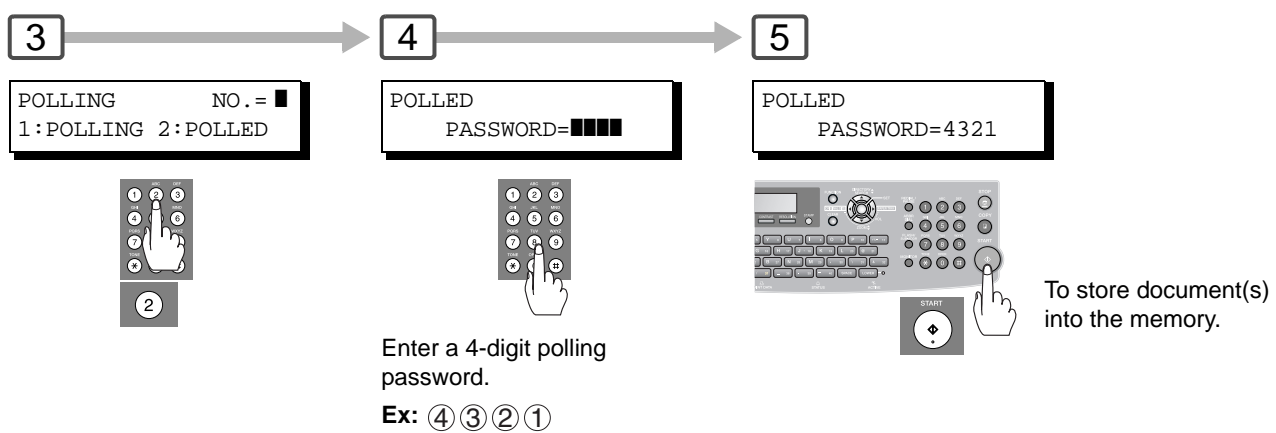

NOTE

5. If a password is not set in the polled station, you may poll the other station even though your machine has a password.



Facsimile Features

Polling

■ Poll Documents from Another Station

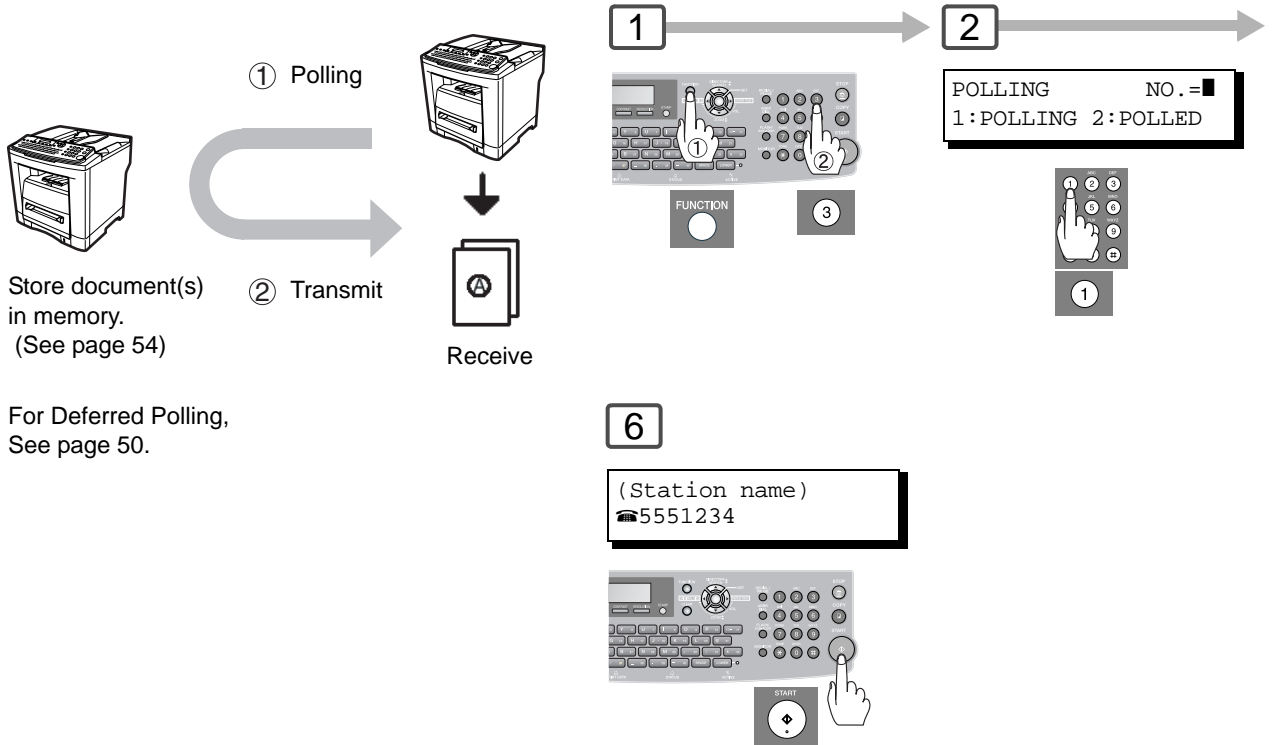

NOTE

1. You can still send or receive documents even when the machine is set to be polled.
2. If you have set the polling password in Fax Parameter No. 26, the password will appear on the display. (see page 111)
You can still change the password temporarily by overwriting it with a new one.

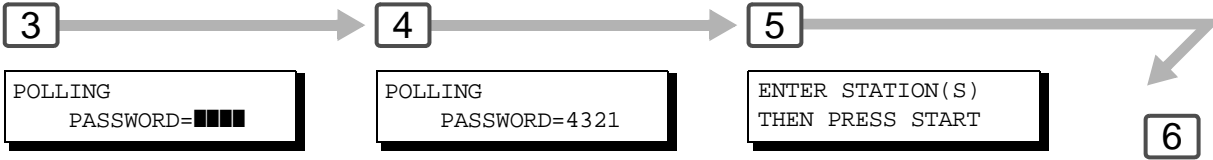

POLLING
PASSWORD=■■■■



Enter a 4-digit polling password.

Ex: ④③②①

POLLING
PASSWORD=4321

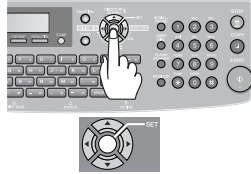

ENTER STATION(S)
THEN PRESS START

- Enter the stations.
- Quick Name Search
 - One-Touch/ABBR. Dialing
 - Manual Number Dialing
 - Directory Search Dialing
(For details, See page 38)

6



Facsimile Features

Program Keys

■ General Description

Your machine has "Program Keys" for your convenience, where each key can be programmed with a frequently used function. For instance, these "keys" are useful if you regularly send or poll the same group of stations. You can use these "keys" to program a group key, a group of stations to be polled, a deferred transmission.

■ Setting for Group Dialing

The Program Keys are useful if you frequently need to send or poll the same group of stations.

Ex. Quick Name Search (Fax Parameter No. 119 default setting is "2:Quick Name Search", See page 112.)

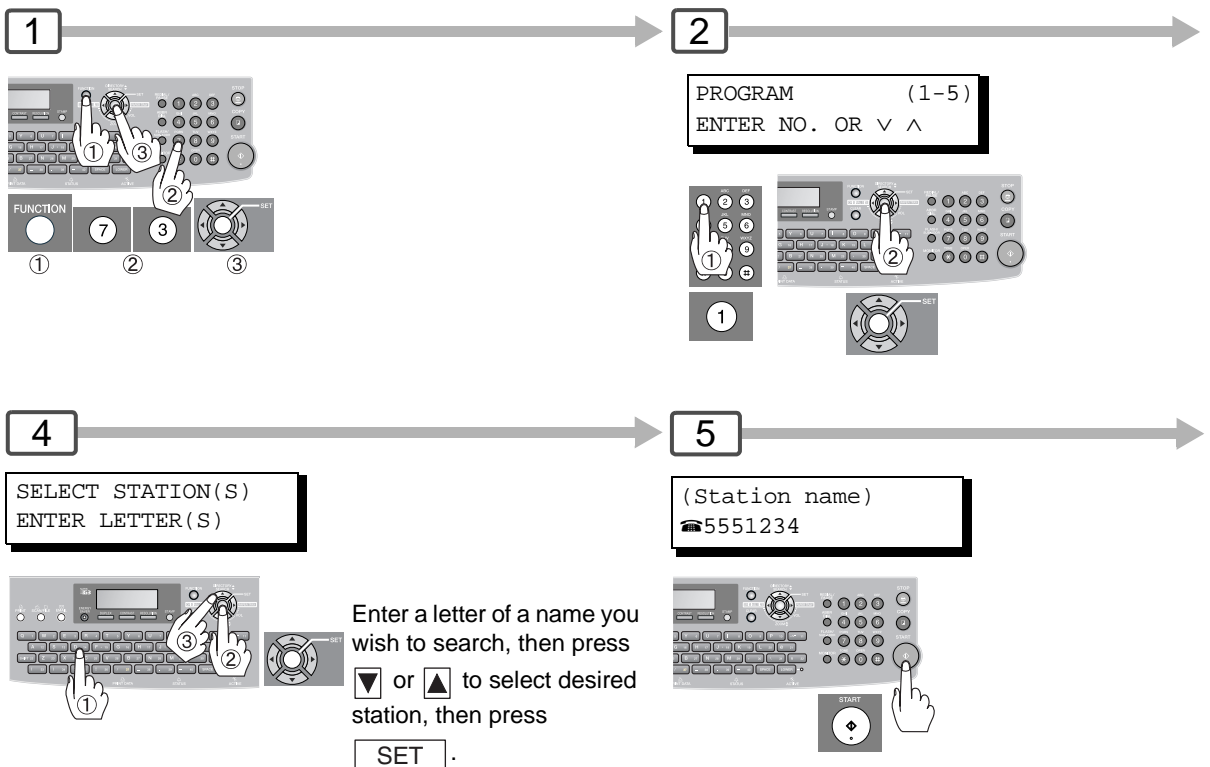

■ Changing the Group Dialing

NOTE

1. The "Program Key" cannot be modified or erased until the communication using it has finished. To change or erase the settings, cancel the communication first by using the Edit File Mode. (See page 78)

3

GROUP NAME
 ENTER NAME

4

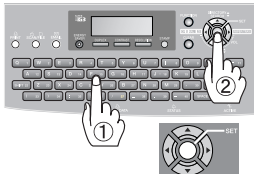

Enter the Group name
(up to 15 characters)
by using the Character keys,
then press **SET** .

Ex: PROG.A

6

You can now set other Program
Keys by repeating the procedures
from Step 3, or return to standby
mode by pressing **STOP** .

NOTE

2. To print a Program List, See page 128.
3. When the Group Dial is registered, the Group Dial mark will display on the LCD and print on the Directory Sheet.



Facsimile Features

Program Keys

■ Setting Programmed Communication

Use "Program Keys" to store multiple stations to be polled, or to set up a deferred transmission.

(This example is when the Fax Parameter No. 119 is set to "2:Quick Name Search" (See page 112).)

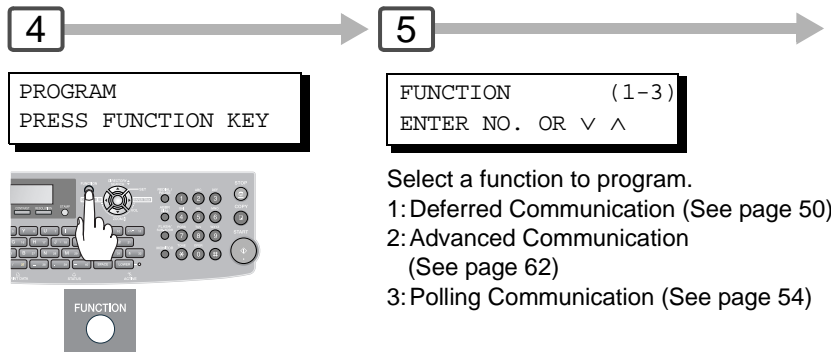
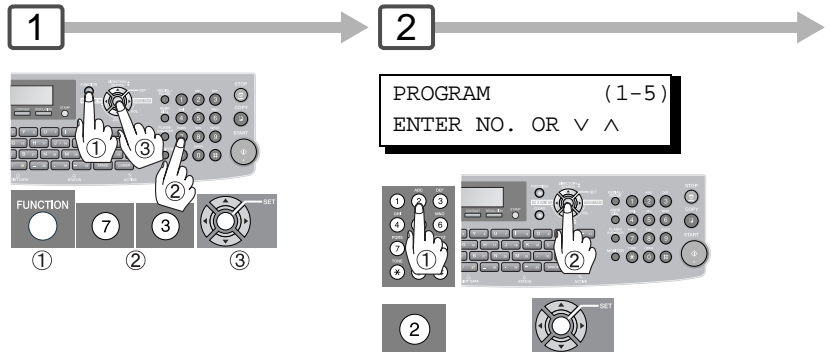

■ Changing the Program Key Setting

To change the below Program key settings, follow the procedure on setting a program key on pages 58 to 61.

- Start time or station(s) for deferred transmission
- Station(s) for normal polling
- Start time or station(s) for deferred polling
- Station(s) for group dialing

NOTE

1. Press **FUNCTION** **7** **3** **SET** **4** to modify (**5**:delete) a Group Dialing or Program Dial.
2. The Group Dialing and Program Key cannot be changed or erased until the communication has finished. To change or erase the settings, cancel the communication first by using the Edit File Mode. (See page 78)

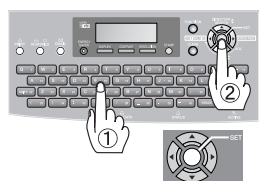

Enter the program name (up to 15 characters) by using the Character keys, then press **SET** .

Ex: PROG.A

6

You can now set other Program Keys by repeating the procedures from Step 3, or return to standby mode by pressing **STOP** .

NOTE

3. To print a Program List, See page 128.



Facsimile Features

Sub-Addressing

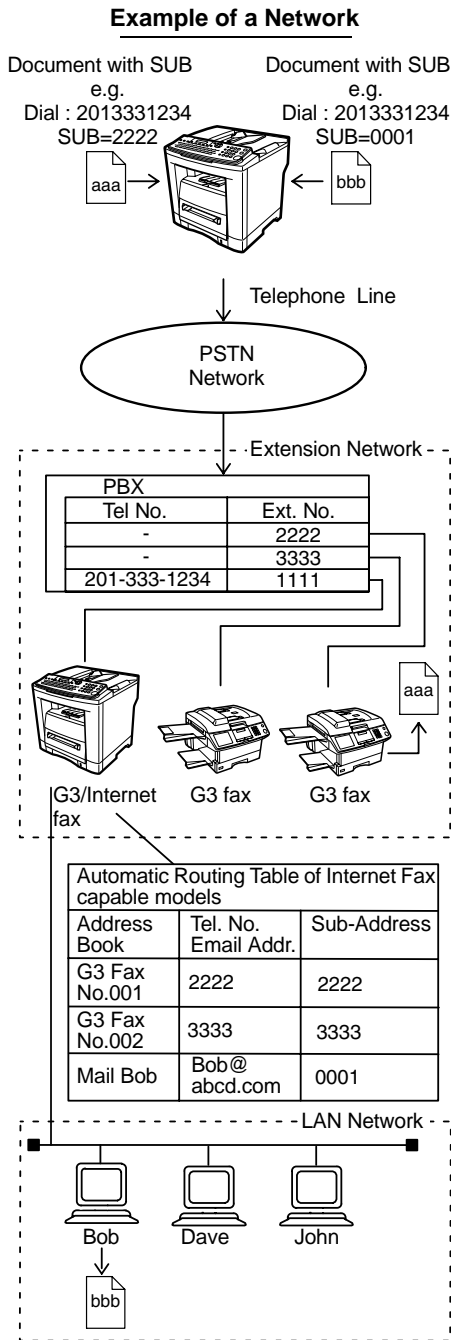

Compatibility with Other Machines

- Sub-Addressing Transmission: KM-F650/KM-F1050/KM-F1060(see note 3)
- Sub-Addressing Reception: KM-F1060 with Internet Fax.

■ Sending a Fax with Sub-Address



■ Setting the Sub-Address into an Address Book

(When Fax Parameter No.119 is set to "2:Quick Name Search", see page 112.)

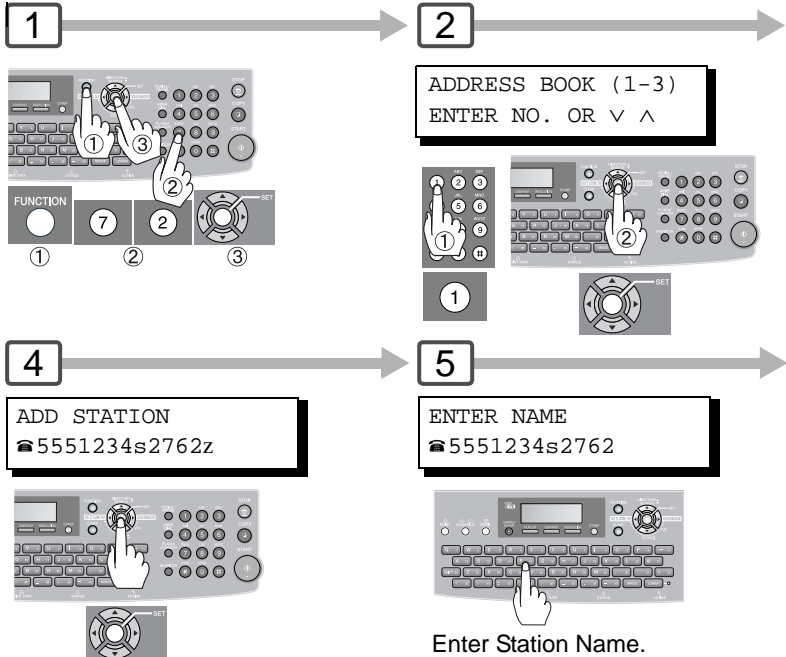

NOTE

1. **SUB-ADDR** separates the Sub-address from the Telephone number and is indicated by an "s" in the display.
2. Manual Off-Hook or On-Hook Dialing cannot be used with the Sub-addressing Transmission.

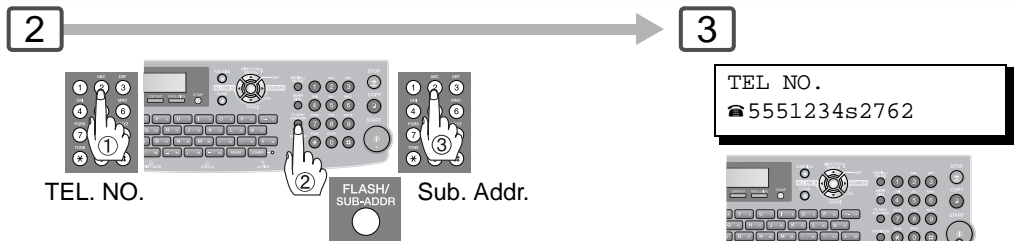

Enter the telephone number, press **[SUB-ADDR]**, then enter the Sub-address. (Up to 20 digits)
 (Up to 36 digits including telephone number, pauses, spaces, FLASH and Sub-address).
Ex: 5551234 **[SUB-ADDR]** 2762

Send the document(s) with Sub-Addressing information. (See Note 4)



Enter the telephone number, press **[SUB-ADDR]** then enter the Sub-address. (Up to 20 digits)
 (Up to 36 digits including telephone number, pauses, spaces, FLASH and Sub-address).
Ex: 5551234 **[SUB-ADDR]** 2762

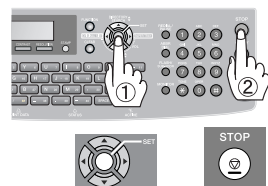
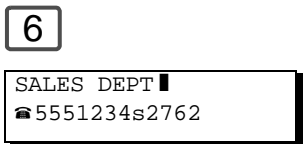

You can send the document using a Address Book Dialing with a preset Sub-Address.

(When Fax Parameter No. 119 is set to "1:One-Touch", you can set as One-Touch/ABBR Dialing.)

NOTE

3. The Sub-Address Password will be sent when Fax Parameter No. 53 (**Sub-Address Password**) is set. (See page 112)

4. You can change a Sub-Address Password temporarily by using **[FUNCTION]** ② ④ **[SET]** .



Facsimile Features

Fax Cover Sheet

■ Using the Fax Cover Sheet

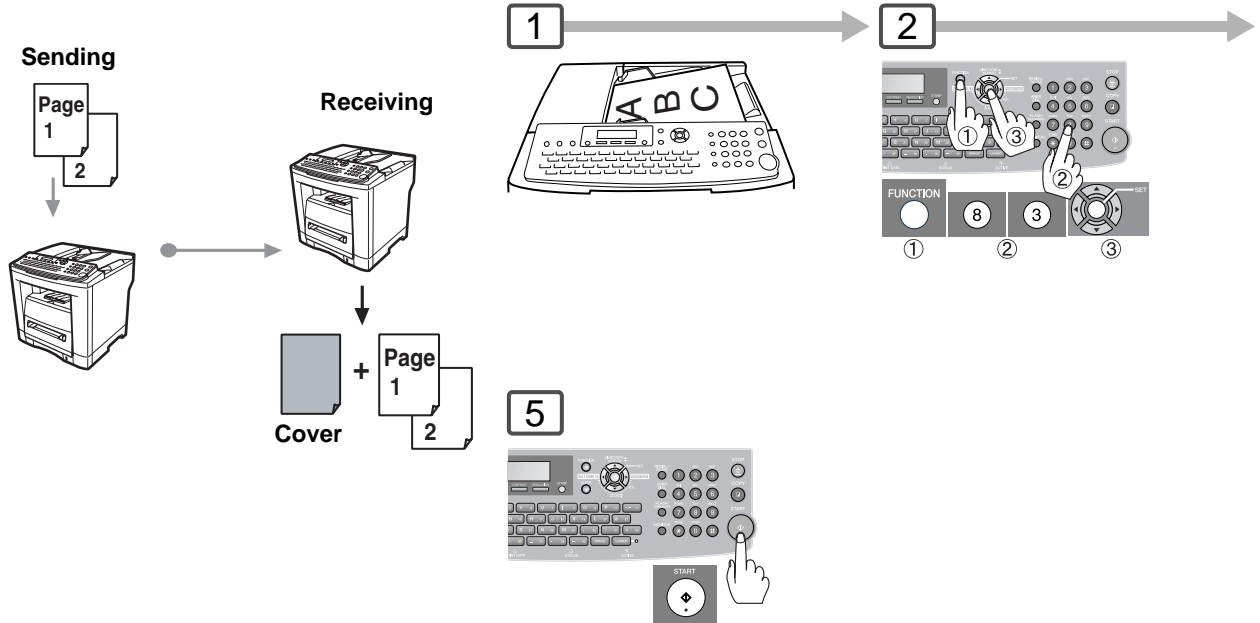

Explanation of Contents

- (1) Starting time of communication.
- (2) Recorded name in the Address Book station.
- (3) Your LOGO (up to 25 characters) and ID Number (up to 20 digits).
- (4) The number of pages to follow.

Sample Fax Cover Sheet

```

***** FACSIMILE COVER SHEET *****

      ( 1 )
      MMM-dd-yyyy 15:00

      ( 2 )
      Message To:
      [ SALES DEPT. ]

      ( 3 )
      Message From:
      [ ABCD ]
      [ 201 555 1212 ]

      ( 4 )
      02
      Page(s)
      Following This Cover Page
  
```

NOTE

- 1. The Fax Cover Sheet is not counted in the number of pages column of the Journal.
- 2. To change the preset Fax Cover Sheet setting, change the setting of Fax Parameter No. 56, See page 112.

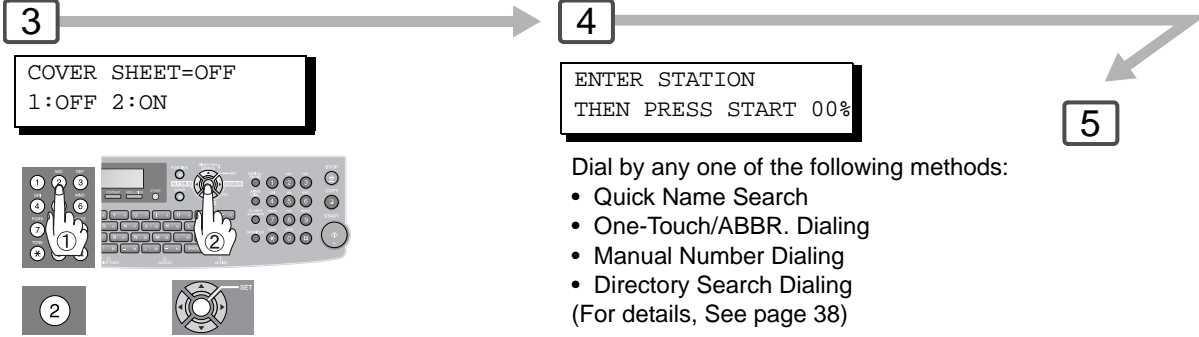

NOTE

3. When the Fax Cover Sheet setting is set to On, the Quick Memory Transmission feature is disabled.



Advanced Facsimile Features

Receive To Memory

■ Setting RCV To Memory Password

This feature is used to secure all received documents by storing them into memory. To print the document(s) received in memory, the authorized operator must enter the correct password.

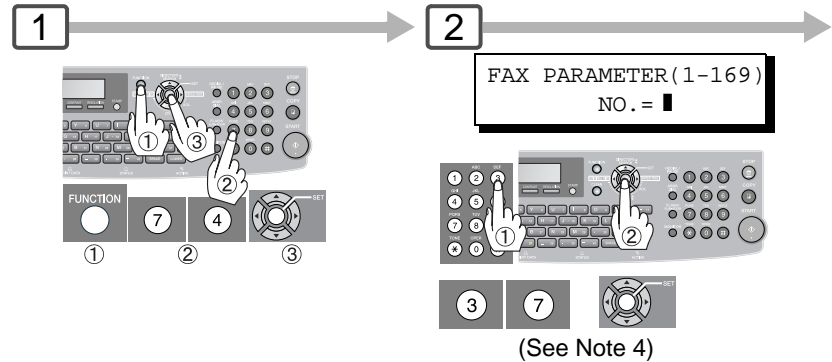
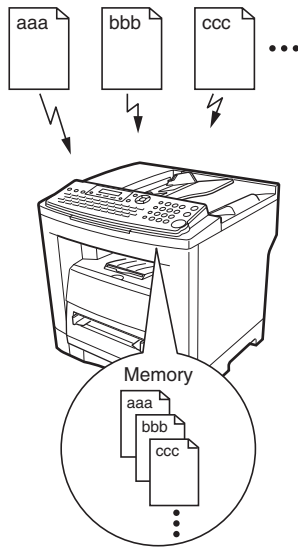

■ Setting the RCV To Memory

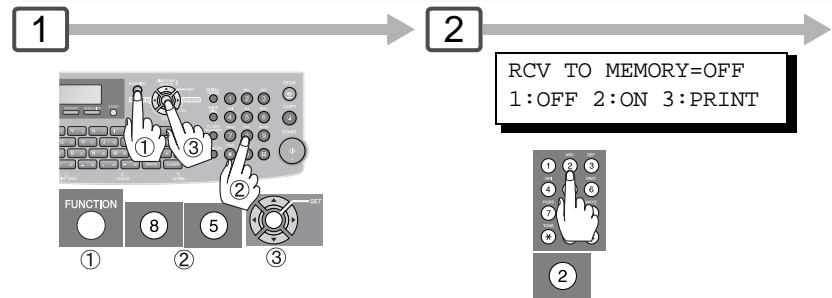

■ Printing Documents

After receiving documents with the Receive To Memory feature, the following message will appear on the display.

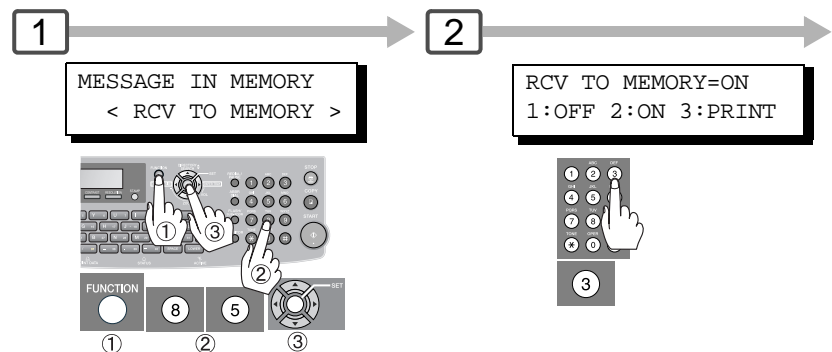

NOTE

1. When the memory overflows, the machine will stop receiving and release the line. The machine will not answer the next incoming call until there is space available in memory.
2. We recommend that optional SD Memory Card is installed when this function is used. See page 140.
3. If the password has not been set, your machine will not prompt you to enter the password. The document(s) will be printed immediately after pressing press **SET** in Step 3.

3 → **4**

37 RCV TO MEMORY █ █ █ █

37 RCV TO MEMORY
1234

4-digit RCV to Memory Password
Ex: 1234

3 → **4**

RCV TO MEMORY=ON
1:OFF 2:ON 3:PRINT

MMM-dd-yyyy 15:00
< RCV TO MEMORY >

3 → **4**

RCV TO MEMORY=PRINT
1:OFF 2:ON 3:PRINT

INPUT PASSWORD █ █ █ █

4-digit RCV to Memory Password
and press **SET** .
Ex: 1234

NOTE

4. Once the RCV TO MEMORY feature is set to "ON", the password cannot be changed (Fax Parameter No. 37 will not be selectable on the LCD display). If you wish to change the password, set the RCV TO MEMORY feature to "OFF" first. Then change the password. (See page 111)



Facsimile Features

PIN Code Access

General Description

If your PBX requires a PIN (Personal Identification Number) code to get an outside line, your machine can be set to prompt the user to enter a PIN Code before any dialing.

Selecting the Access Method (Prefix or Suffix)

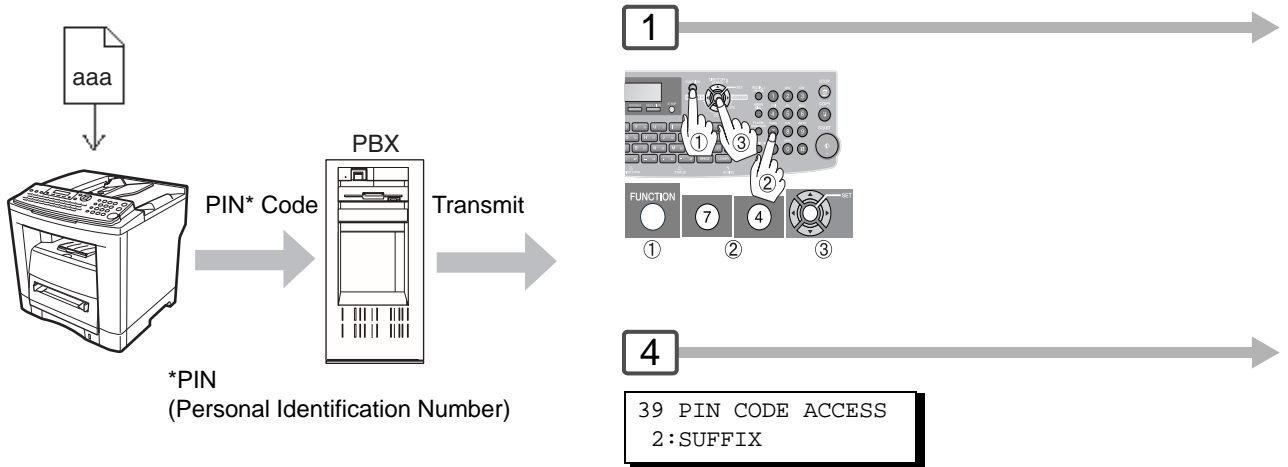

Dialing with a PIN Code

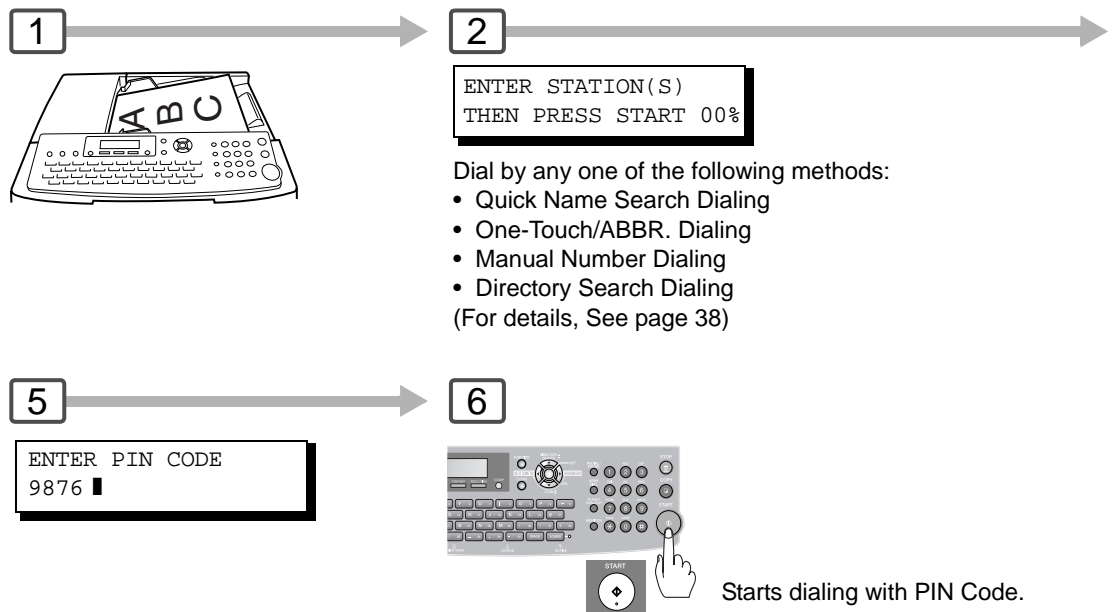

NOTE

1. The PIN Code is shown as "■" on the display when dialing the number for security.

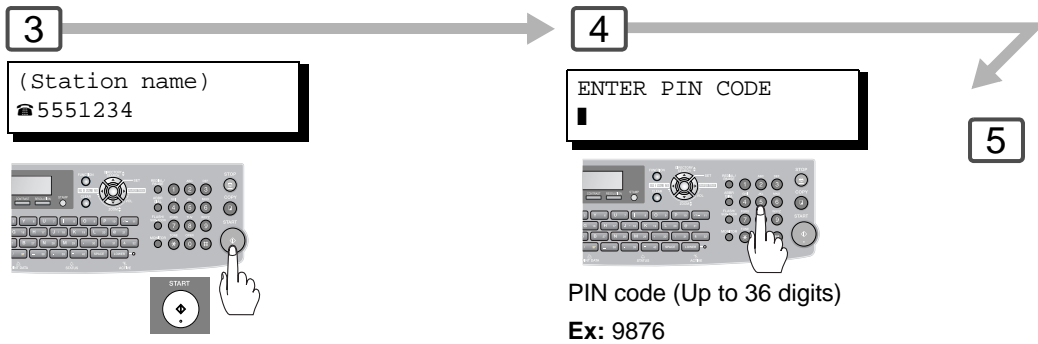
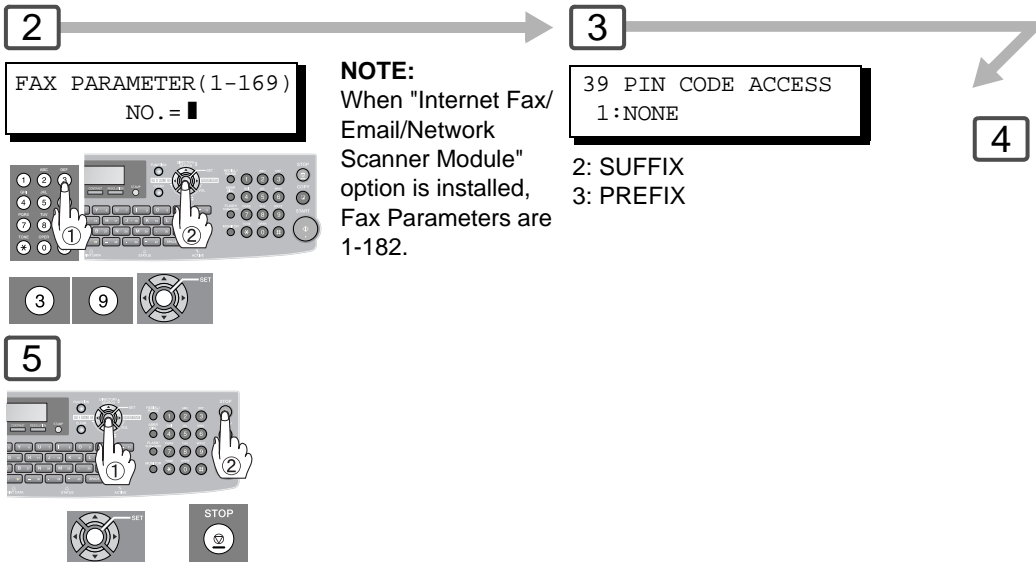

NOTE

2. This feature is not available when dialing a number in the Off-Hook or On-Hook Direct Dialing mode.



Facsimile Features

Department Code

■ General Description

This operation requires the user to input a preset Department Code (8-digit maximum) before transmission. The Department Name of the selected Department Code is printed on the Header of each page sent, COMM. Journal and Individual Transmission Journal.

When the Department Code is set, the Transaction Journal will be sorted by the Department Code number (1 - 50) when it is printed.

■ Setting the Department Code

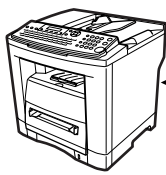

Requires the input of a preset Department Code (8-digit).

Department Code is printed.



Reception

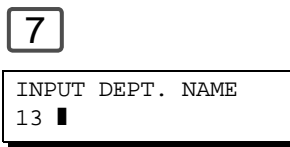
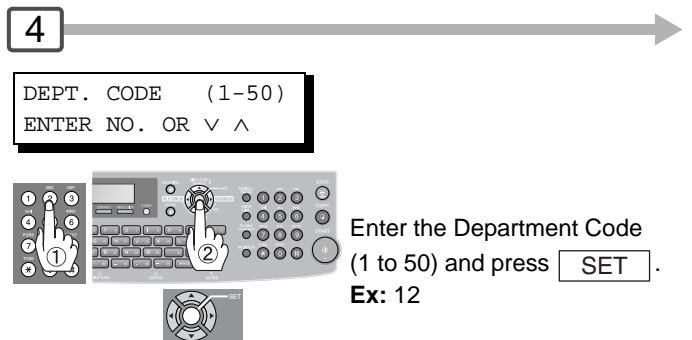
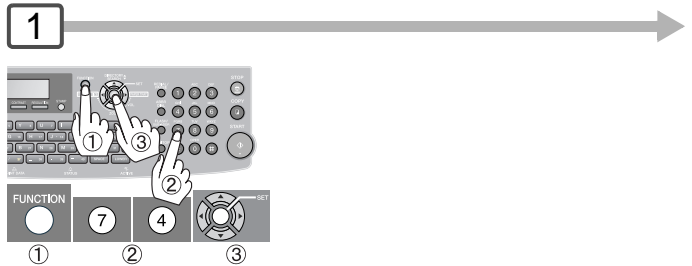

To record another Department Code, repeat from Steps 5 to 6.

To return to standby, press [STOP] .



NOTE

1. The Department Code List can be printed out with the Fax Parameter List. To enable the printing of the Department Code List, change the setting of Fax Parameter No. 77 (**Department Code**) to "Valid" in advance. (See pages 72 and 112)

2

FAX PARAMETER (1-169)
NO. = █

NOTE:
When "Internet Fax/
Email/Network
Scanner Module"
option is installed,
Fax Parameters are
1-182.

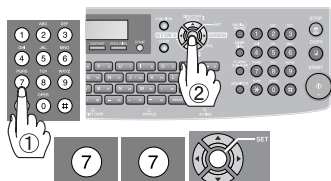

3

77 DEPARTMENT CODE
1: INVALID

4

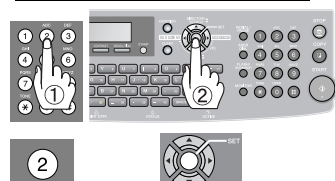

2: VALID

5

INPUT DEPT. NAME
12 █

Department Name (Up to
25 characters) and press
SET .
Ex: ABCD

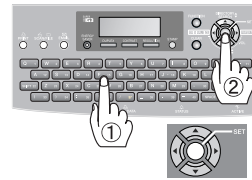

6

INPUT DEPT. CODE
12 █

Up to 8-digit
Department Code
Ex: 12345678

7

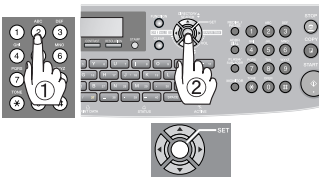



Facsimile Features

Department Code

■ Changing or Erasing the Department Code

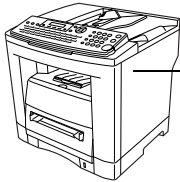

Requires the input of a preset Department Code (8-digit).

1

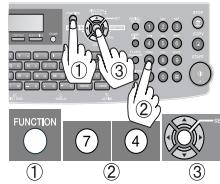

2

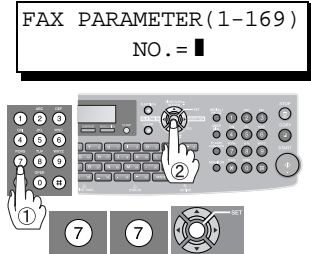

5

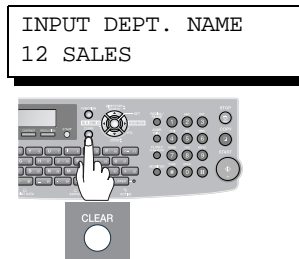

CLEAR then enter a new Name and press **SET** .
Ex: ABCD

If you wish to erase the Department Code, press **SET** after pressing **CLEAR** . Go to Step 7.

■ Sending Document with Department Code

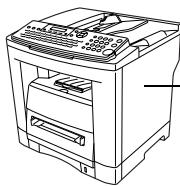

Requires the input of a preset Department Code (8-digit).

1



2

Dial by any one of the following methods:

- Quick Name Search
- One-Touch/ABBR. Dialing
- Manual Number Dialing
- Directory Search Dialing

(For details, See page 38)

5



The document is sent with the header of the selected Department Name. The selected Department Name is printed on the COMM. Journal and Individual Transmission Journal.

3

77 DEPARTMENT CODE
2:VALID

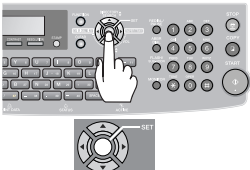

4

DEPT. CODE (1-50)
ENTER NO. OR ∨ ^



5

Enter the Department Code number you wish to change or erase (1 to 50), and press **SET**.

Ex: 12

6

INPUT DEPT. CODE
12 (Previous Code)

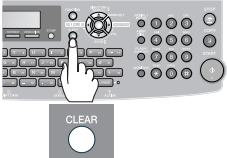

CLEAR then enter a new Department Code and press **SET**.

Ex: 12345678

7

INPUT DEPT. NAME
13 ■

To change or erase another Department Code, repeat from Steps 5 to 10. To return to standby, press **STOP**.

3

(Station name)
☎551234



4

INPUT DEPT. CODE
■



5

8-digit Department Code
Ex: 12345678



Facsimile Features

Department Code

■ Printing a Department Code Journal

Sample Department Code Journal / Originated Calls

```

***** -DEPT CODE JOURNAL- ***** DATE MMM-dd-yyyy ***** TIME 15:00 *** P.01

ORIGINATED CALLS
MMM-dd TO MMM-dd (1)
(2) (3)
TOTAL PAGES = 000038 TOTAL TIME = 00:23:56

(4) (5)
01: Sales
-----
NO. COMM. PAGES FILE DURATION X/R IDENTIFICATION DATE TIME DIAGNOSTIC

001 OK 005 00:05:13 XMT ☎ 5551234 MMM-dd 15:10 C0044903C0000
021 OK 021/021 019 00:10:15 FWD FAX FORWARD MMM-dd 18:10 C0044903C0000
(6) (7)
TOTAL PAGES = 000026 TOTAL TIME = 00:15:28

02: Service
-----
NO. COMM. PAGES FILE DURATION X/R IDENTIFICATION DATE TIME DIAGNOSTIC

019 OK 001/001 017 00:00:13 XMT ☎ 5551234 MMM-dd 10:10 C0044903C0000
030 OK 011/011 045 00:08:15 XMT SERVICE DEPT. MMM-dd 13:10 C0044903C0000

TOTAL PAGES = 000012 TOTAL TIME = 00:08:28

-ABCD -
***** KM-F1060 ***** -HEAD OFFICE- ***** - 201 555 1212 - *****

```

Sample Department Code Journal / Received Calls

```

***** -DEPT CODE JOURNAL- ***** DATE MMM-dd-yyyy ***** TIME 15:00 *** P.02

RECEIVED CALLS
MMM-dd TO MMM-dd (1)
(2) (3)
TOTAL PAGES = 000011 TOTAL TIME = 00:13:41

NO. COMM. PAGES FILE DURATION X/R IDENTIFICATION DATE TIME DIAGNOSTIC

055 OK 005 00:05:13 RCV 4445678 MMM-dd 12:10 C0044903C0000
056 OK 005/005 020 00:08:15 PLD 111 222 333 MMM-dd 19:15 C0044903C0000

070 OK 001 017 00:00:13 RCV 44567345 MMM-dd 10:10 C0044903C0000

-ABCD -
***** KM-F1060 ***** -HEAD OFFICE - ***** - 201 555 1212 - *****

```

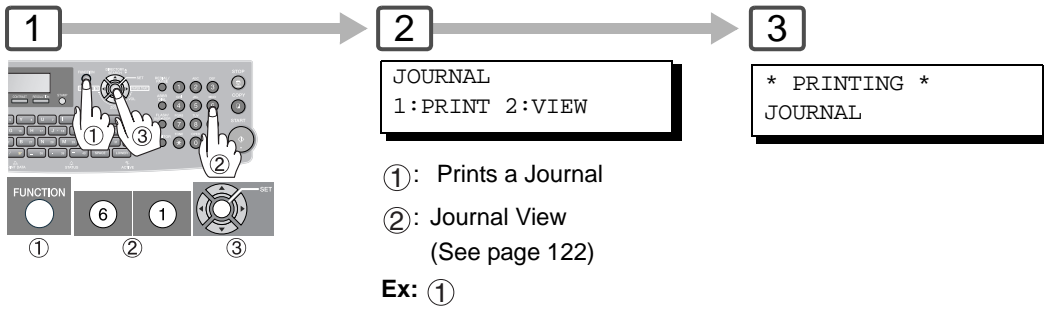

Explanation of Contents

- (1) Period date of this journal.
- (2) Number of total pages transmitted/received for this machine.
- (3) Total transmitted/received time for this machine.
- (4) Department Code.
- (5) Department Name.
- (6) Total number of pages transmitted/received for this department.
- (7) Total transmitted/received time for this department.



Facsimile Features

Edit File Mode

General Description

Your machine has a document image memory which enables you to reserve memory transmission, memory deferred transmission, memory polling and so on.

After reserving the communication job as "FILES" in memory, you may need to change the settings of the communication(s) while it is still in memory.

This section describes how to use the file editing features.

Printing or Viewing a List

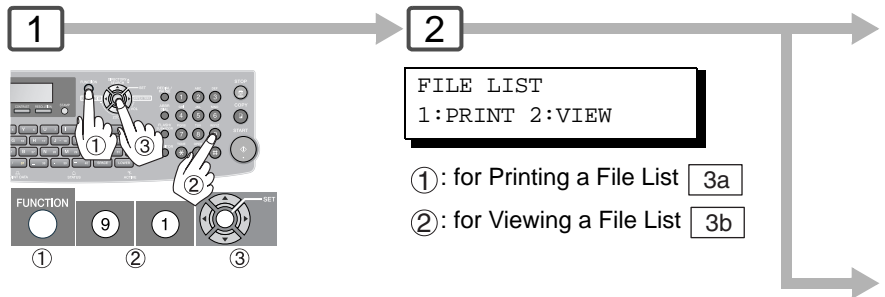

Sample File List (when Fax Parameter No. 119 is set to "2: Quick Name Search", see page 112.)

```

***** -FILE LIST- ***** DATE MMM-dd-yyyy ***** TIME 15:00 *****
(1)  (2)      (3)      (4)      (5)  (6)
FILE  COMM. TYPE   CREATED TIME  START TIME  PAGES DESTINATION(S)
No.

001  DEFERRED XMT   MMM-dd 13:20  20:30      [SALES      ]
002  MEM. DEF. XMT  MMM-dd 13:20  22:30      003 [AMERICA   ] [ASIA      ]

                                -ABCD                -

***** KM-F1060 ***** -HEAD OFFICE - ***** - 201 555 1212- *****

```

Explanation of Contents

- | | |
|------------------------------|---|
| (1) File number | If the file is now being executed, a "*" is indicated on the left of the file number. |
| (2) Communication type | |
| (3) Created date/time | Date/time when these files are created. |
| (4) Executing time | If the file is a Timer Controlled Communication, the start time is printed in this column. If the file is an incomplete file, "INCOMP" is printed in this column. |
| (5) Number of stored page(s) | |
| (6) Destination | Station Name/ABBR. No./One-Touch No./Manual Dialing No./Email Address |

3a

```
* PRINTING *
FILE LIST
```

3b

```
USE THE ∨ ^ KEYS TO
SCROLL EACH FILE
```

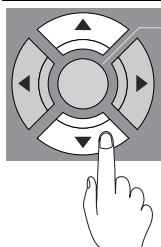

Sample Display

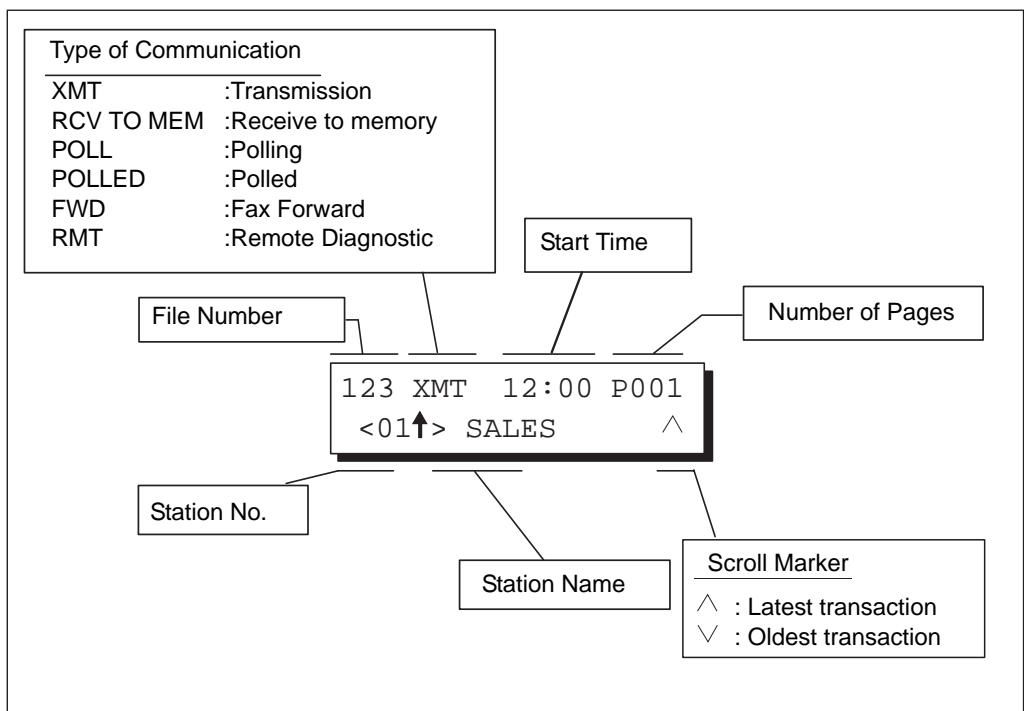



Facsimile Features

Edit File Mode

■ Changing the Start Time or the Station of a File

Use the following procedure to change the start time and/or stations in a communication file.

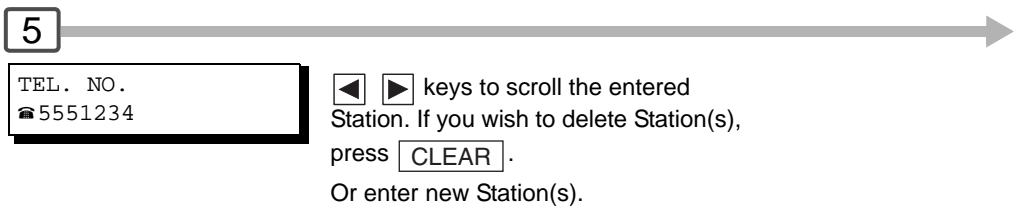
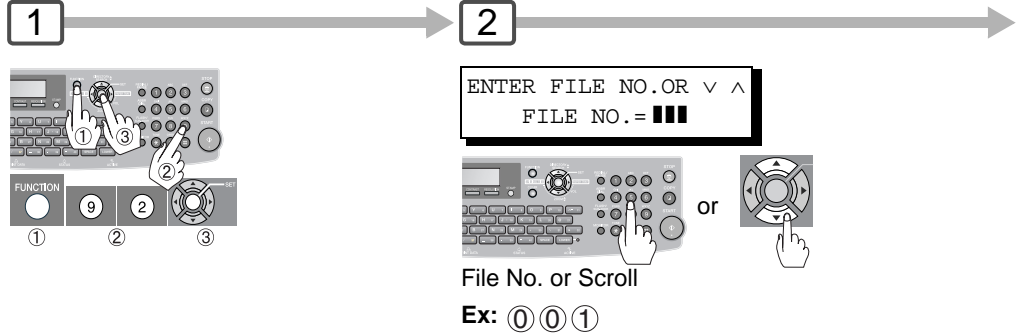

■ Deleting a File

Use the following procedure to delete the file from memory.

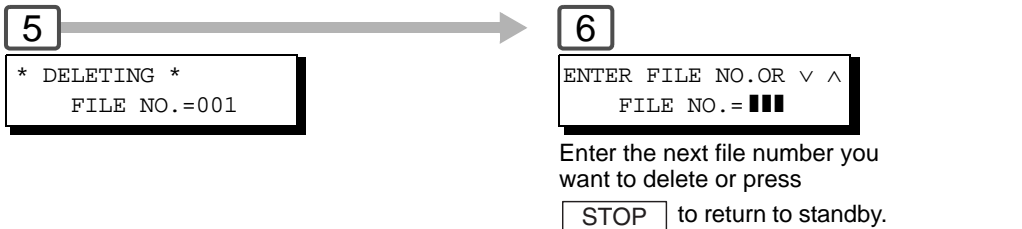
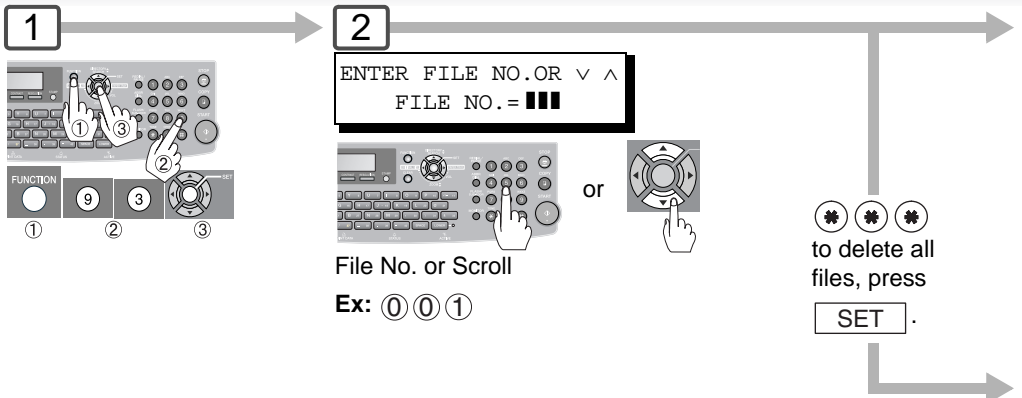

NOTE

1. Your machine cannot delete the file while it is being sent.
2. If the file is not a Deferred Communication File, the following message is shown on the display.

SET DEFERRED COMM. ?
1: YES 2: NO

Press 1 to change the file type to deferred communication.

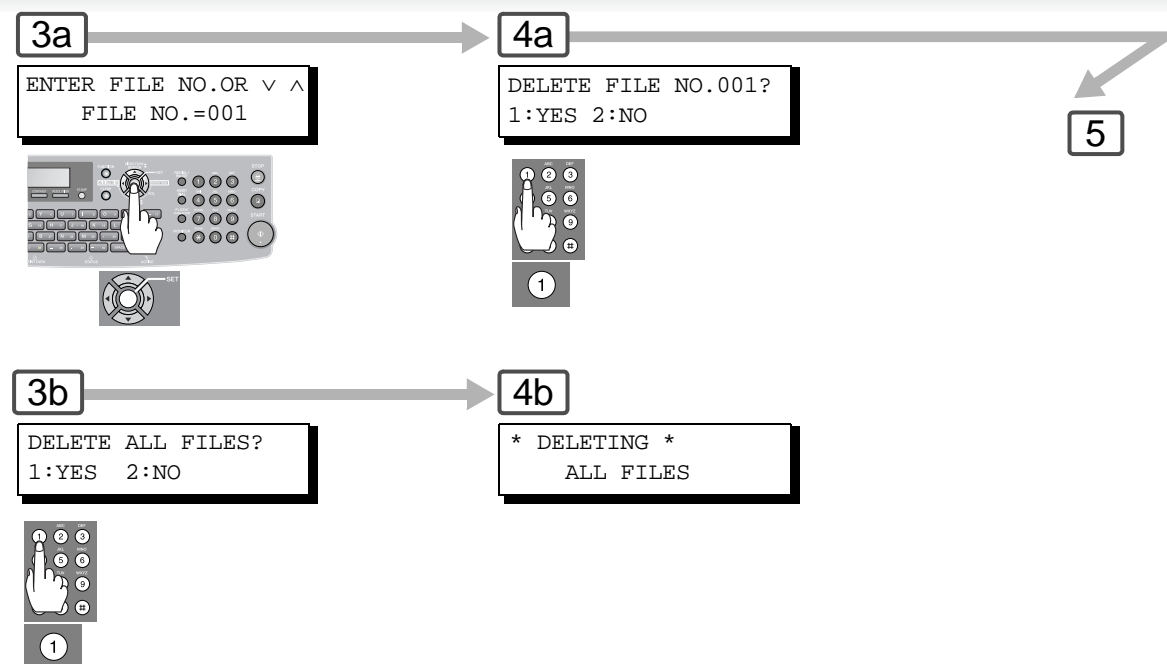
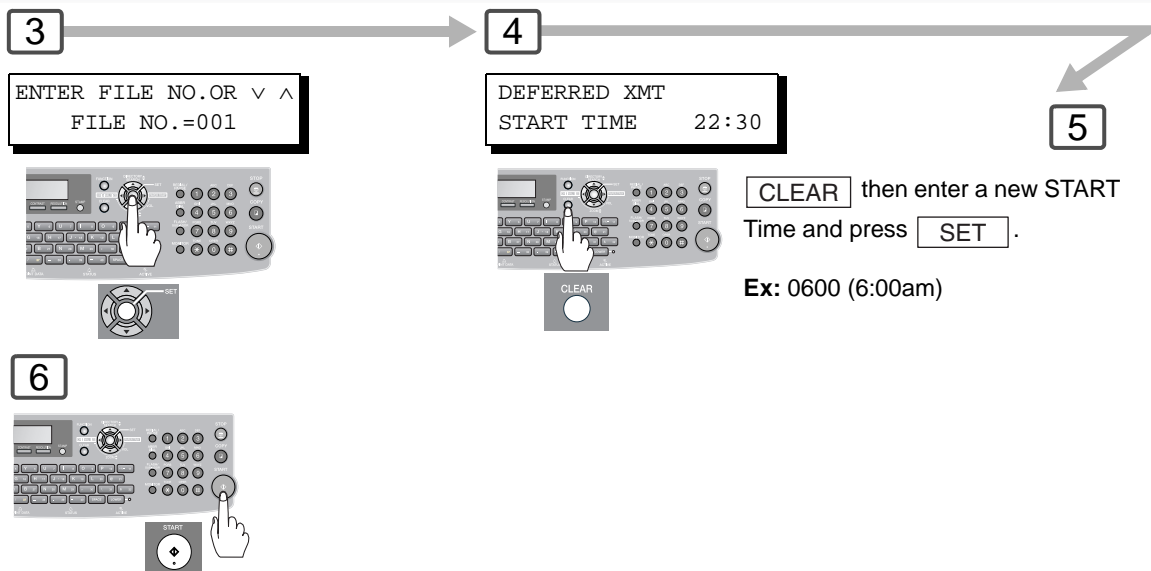

NOTE

3. If you edit the file that is saved as an incomplete file, after pressing **START** in Step 6, your machine will prompt you whether to execute the file immediately.
The display shows:

RETRY INCOMP FILE?
1: YES 2: NO

Press ① to execute the file immediately.

4. If using "DELETE ALL FILES", it takes several minutes.



Facsimile Features

Edit File Mode

■ Printing Out a File

Use the following procedure to print the contents of the communication file.

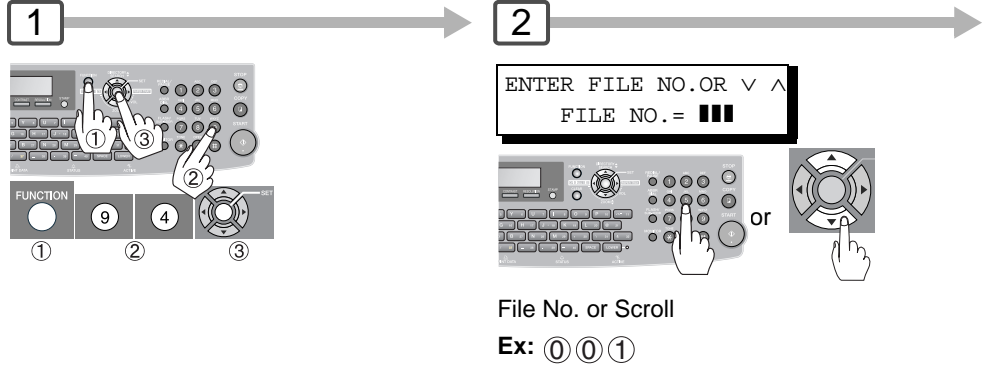

■ Adding Documents into a File

Use the following procedure to add documents into the file.

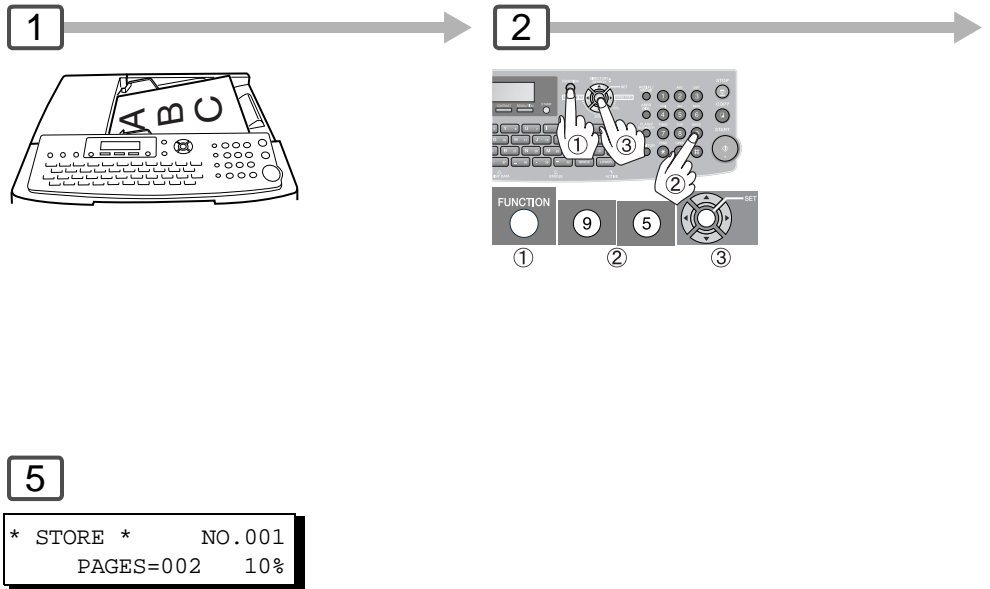

NOTE

1. Your machine cannot print the file while it is being sent.
2. Your machine cannot add document(s) into a file while it is being sent or waiting to redial.

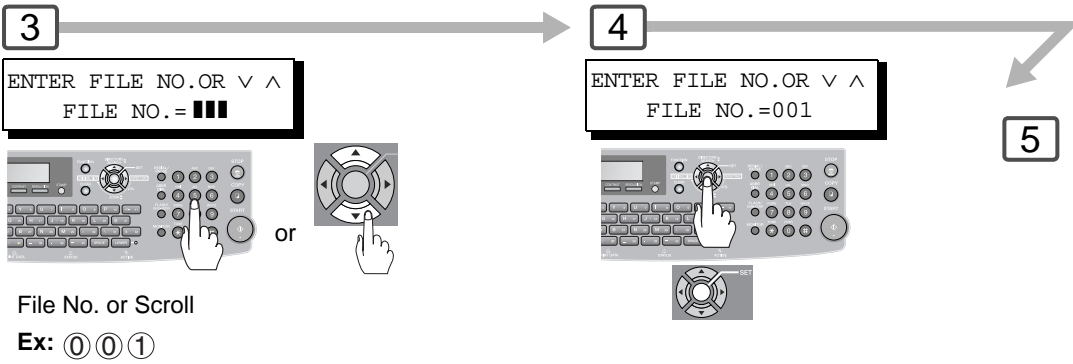
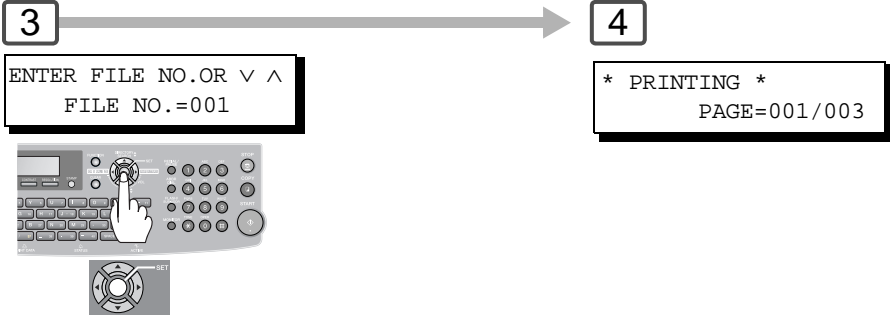



Facsimile Features

Edit File Mode

■ Retry an Incomplete File

If a memory communication has been unsuccessful due to a busy line or no answer, the document you stored is automatically erased from memory after the last redial.

If you need to retain the document even if the communication failed, change the setting of Fax Parameter No. 31 (**Incomplete File Save**) to "**Valid**" in advance. (See page 111)

Use the following procedure to retry the incomplete file.

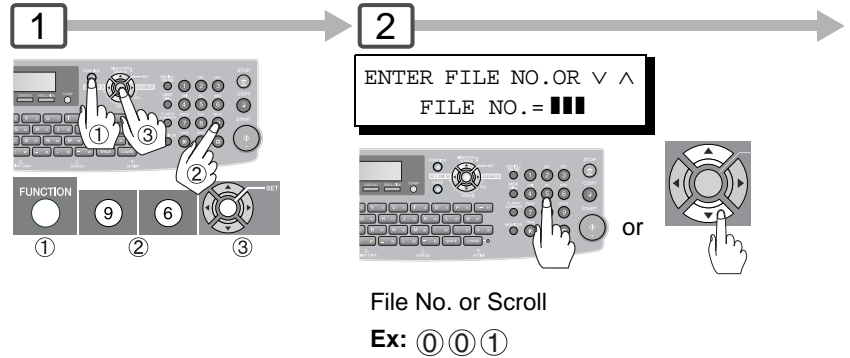

NOTE

1. If you set Fax Parameter No. 31 to "**Valid**", all incomplete files will remain in memory. To avoid memory overflow, please check the memory content frequently.

3

ENTER FILE NO.OR ∨ ^
FILE NO.=001

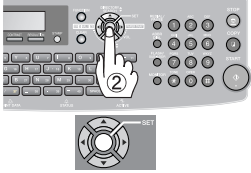

4

* STORE * NO.001
(Station name)

* DIALING * NO.001
(Station name)



Facsimile Features

Access Code

■ General Description

The Access Code prevents an unauthorized user from operating the machine. Once a 4-digit Access Code is registered, no one can operate the machine without entering the correct access code. Automatic Receiving, however, is always available. After you complete any operation, such as mode setting or transmission, and the display returns to standby, you have to reenter the access code in order to use the machine again. Registering the Access Code does not affect the use of the machine in any other way.

■ Setting the Access Code

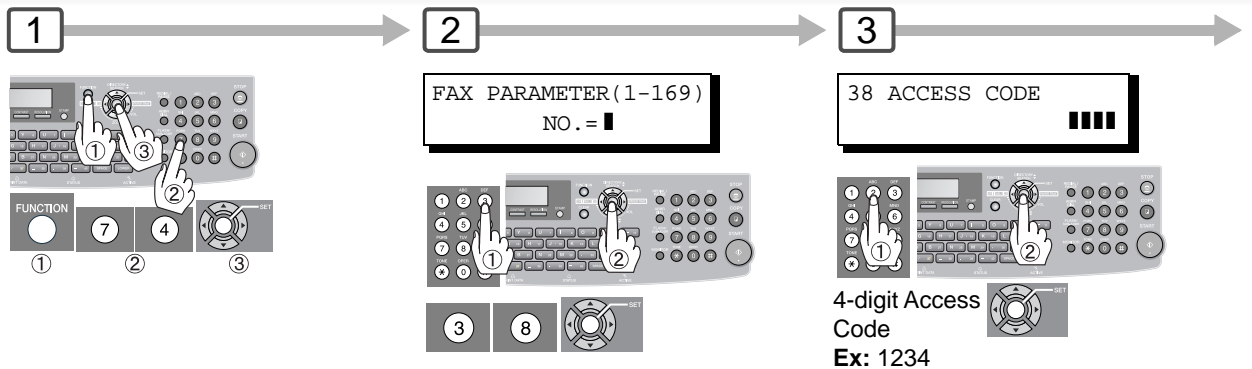

■ Operating FAX with the Access

Restrict all Operatings

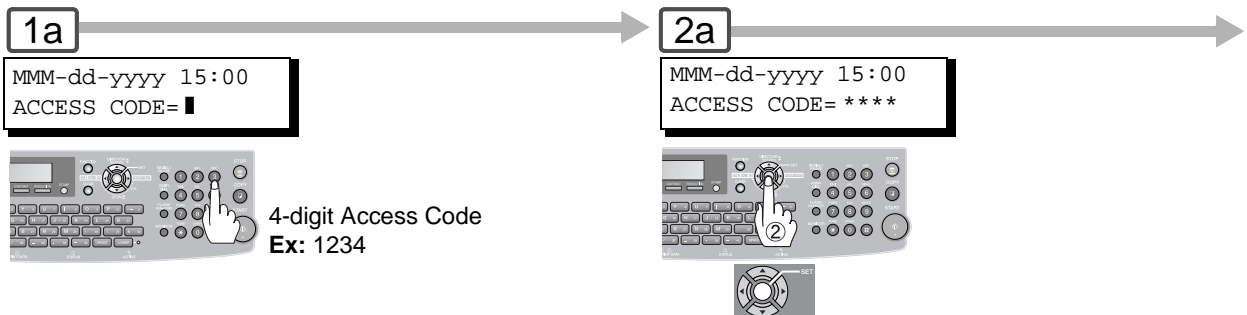

Restrict the Operation of Setting/Printing the Fax Parameters Only

(Ex: When setting the Fax Parameter.)

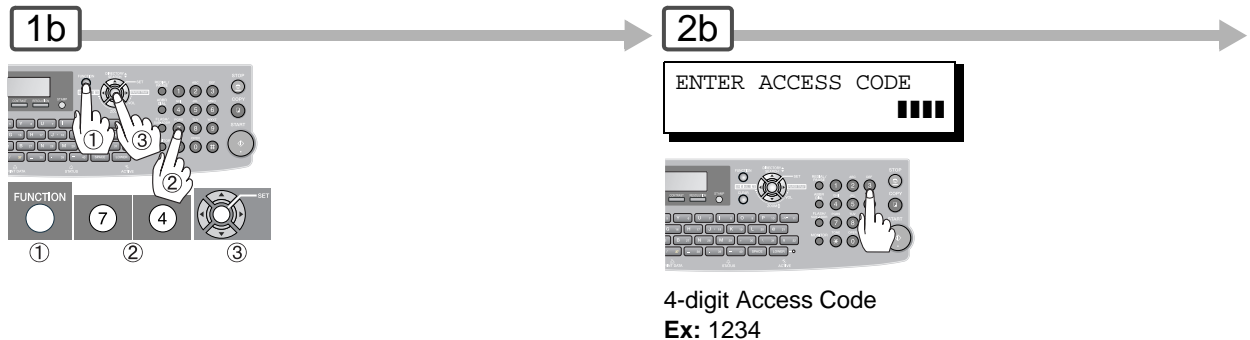

NOTE

- To erase the Access Code, enter the Access Code and press **SET** and follow the procedure above to Step 2, then press **CLEAR**, **SET** and **STOP**.



4 → **5**

38 ACCESS CODE
1: ALL 1234

38 ACCESS CODE
2: PARAMETERS 1234

Select Restriction Level.
1: All;
or
2: Parameters;
Ex: 2: Parameters



→ **4**

MMM-dd-yyyy 15:00
00%

or



FAX PARAMETER(1-169)
NO. = █

Now you can operate the machine normally.

NOTE:
When "Internet Fax/Email/Network Scanner Module" option is installed, Fax Parameters are 1-182.

3b

ENTER ACCESS CODE



Facsimile Features

Dial Prefix

General Description

Your machine has the following functions to utilize your existing database for Fax Phone Numbers.

- LDAP database search for fax phone numbers (Directory Search)
- Import an existing fax phone number list in CSV file format (Network Address Book Editor software)

Since the phone numbers in such database are usually 10-digit numbers that are not the same as the numbers to be actually dialed through your PBX.

(Example)

- A fax phone number in the database ' 212 555 1234
- A fax phone number to be dialed via PBX, if you are outside 212 calling area ' 9+[PAUSE]+1+212 555 1234

Dial prefix function allows you to program a Dial Prefix including PBX Dial-out Prefix (e.g. "9") and Long Distance Call Code (=1) and pre-programmed Dial Prefix will be automatically dialed only when the fax phone number is a 10-digit number so that you can utilize the existing database without modifying them. To enable this function, the Fax Parameter No.122 is to be set to "Valid". (See page 113)

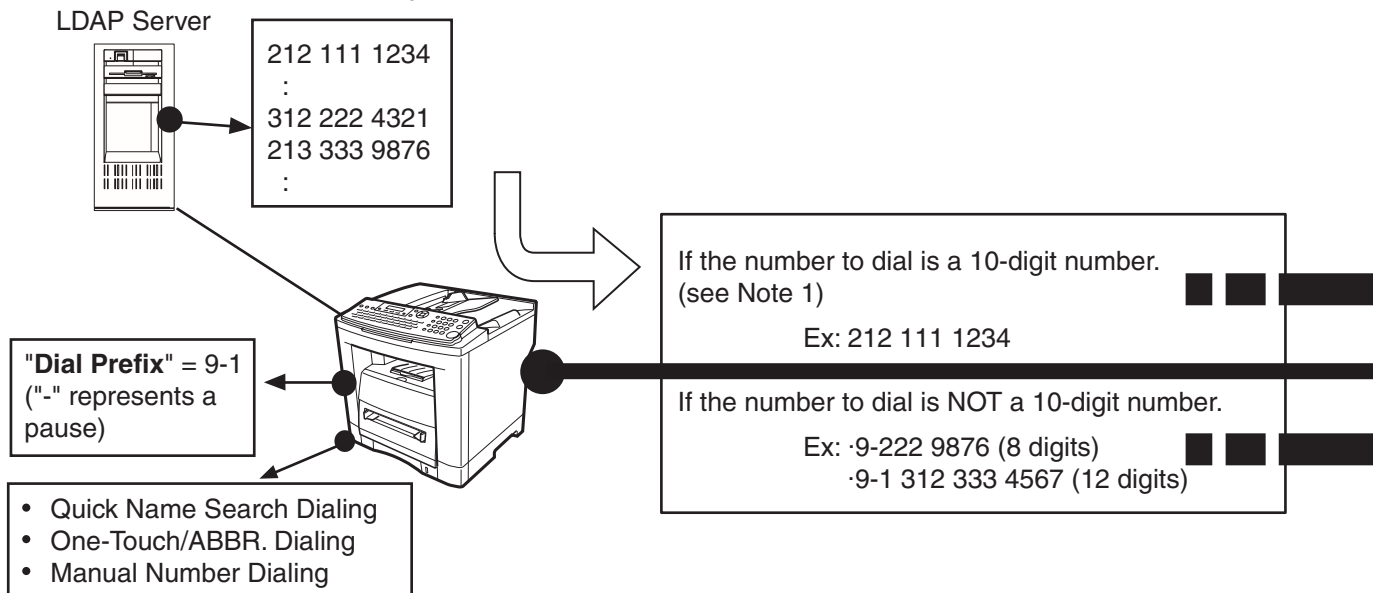

Setting the Dial Prefix

Restrict all Operatings

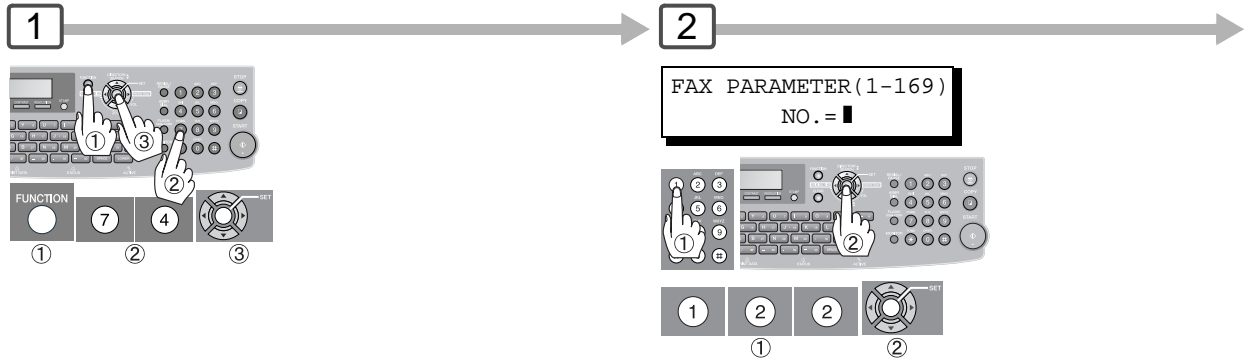

NOTE

1. Only numbers (0 to 9) will be counted for 10 digits. Any other characters or symbols (such as "-" will be ignored.)

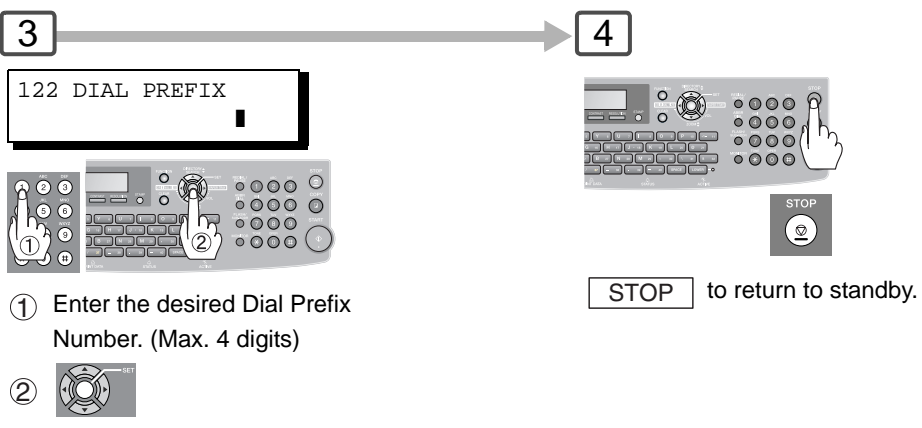
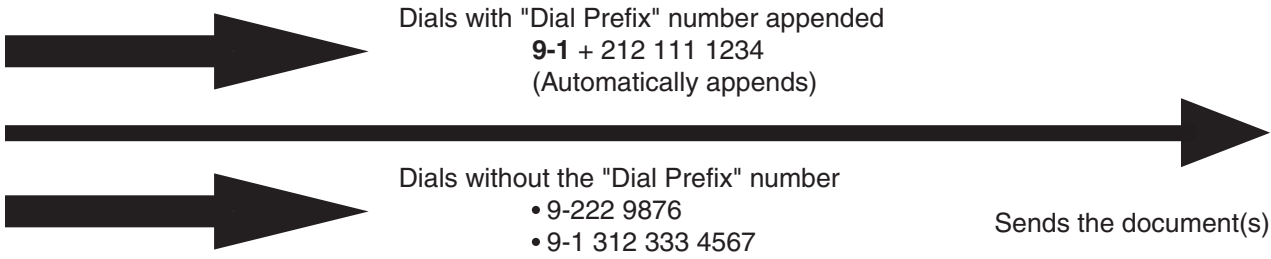

NOTE 2. This function is not available when using Monitor Dialing or off-hook dialing either with the optional handset or an external telephone set.

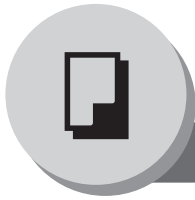

Copy Features

Basic Copy

■ Copying the Same Size Originals (1:1)

Copy size is automatically selected.

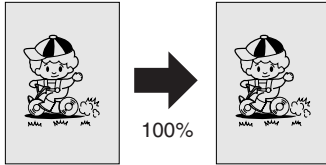

1

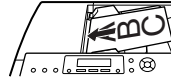

2



- ① COPY
- ② ORIGINAL SIZE
- LTR : Letter-R
- INV : Invoice
- INV : Invoice-R
- LGL : Legal
- MIX : Letter and Legal (See Note 1)

■ Multi-Size Feeding (MIX)

Use this function when copying mixed (Legal & Letter) size originals through the ADF. The original's size is automatically detected and copied in full size. (See Note 2)

■ Sort Mode

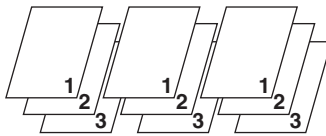

Sort

Multiple sets of copies will be made and sorted in the original's page order.

Non-Sort

Multiple copies of each original will be made non sorted.

NOTE:

Initial Sort Mode settings can be selected within the Function Settings. (See page 116) Copier Setting No. 10 to "2:Sort"

■ Copying with Variable or Preset Zoom Ratios

Variable Zoom Ratios

Copies with variable zoom ratios from 71 % to 141 % in 1 % increments.

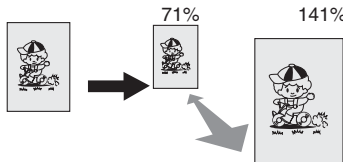

Preset Ratios (ex: Reduction)

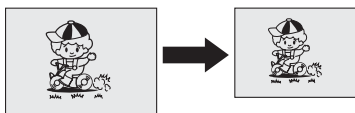

Letter

Invoice

NOTE:

When the paper size is indicated "****", load paper to the Sheet Bypass. (See page 26)

1



2



- ① COPY
- ② ORIGINAL SIZE
- LTR : Letter-R
- INV : Invoice
- INV : Invoice-R
- LGL : Legal
- MIX : Letter and Legal (See Note 1)

NOTE

1. This function is available only when the optional Tray-2 is installed and both Legal and Letter-R size papers are loaded in Tray-1 and Tray-2 respectively.

3 → **4**

After pressing the **CONTRAST** Key, use the **Cursor Keys** to adjust the **Manual Exposure**.

CONTRAST
- [■■■] +

◀ : Lighter ▶ : Darker

4

Number of Copies (Max. 999)

START or COPY

■ Using the ADF

Originals that cannot be used

- Post Cards, Drawing Papers, Transparencies, Labelling Papers, Heavyweight Papers, Thin Art Papers, Film, Thermal papers

Inappropriate Originals

- Paper with a smooth surface such as glossy and coated papers
- Originals with a Lead Edge that is ripped, creased, folded, punched, or glued.
- Mixed width Originals
- Post-it Notes
- Pressure sensitive or carbon backed papers
- Paper with excessive curl
- Stapled originals
- Freshly printed copies from a laser printer
- Originals with fresh White-Out (Liquid paper correction fluid)

Upper Limit Indicator (A)

Upper Limit Guide (B)

Set the originals up to the upper limit indicator (A) and guide (B)

ADF Tray

Original Guides
Adjust to the original's width.

3 → **4**

<Reduction>
ex. Legal Size Original

LGL [] ŸLGL [****]
ADD PAPER

Press ▼ Key.

LGL [] [****]
ZOOM: 99% COPIES: 001

Press and Hold ▼ Key.

LGL [] ŸLTR [LTR [] 1]
ZOOM: 79% COPIES: 001

<Enlargement>
ex. Invoice Size Original

INV [] ŸINV [****]
ADD PAPER

Press ▲ Key.

INV [] [****]
ZOOM: 101% COPIES: 001

Press and Hold ▲ Key.

INV [] ŸLTR [LTR [] 1]
ZOOM: 129% COPIES: 001

▲ Up to 141% in 1%
▼ Down to 71% in 1%

Number of Copies (Max. 999)

START or COPY

NOTE:
Press **STOP** Key to exit this mode.

NOTE

2. The default original size is "LETTER". If you use the Multi-Size Feeding function, change the default original size to "MIX" in the Copier Setting for key operator, Parameter No. 13 (ORIGINAL SIZE). (See page 117)

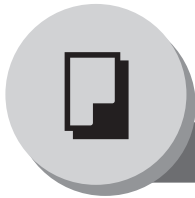

Copy Features

Creative Features

1→2 Copy

1-Sided → 2-Sided Copy

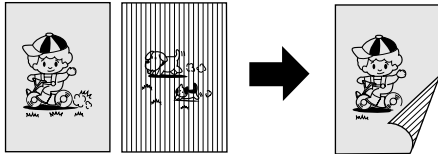

NOTE:

When using the Sheet Bypass, 1→2 Copy function is not available.

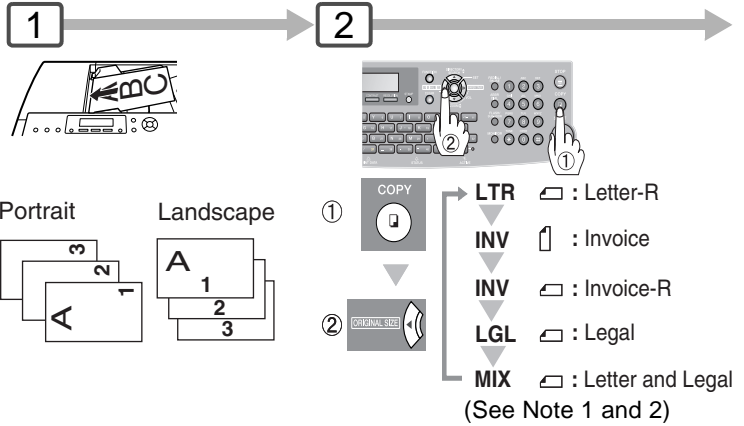

2→2 Copy, 2→1 Copy

2 → 2 Copy 2-Sided → 2-Sided Copy

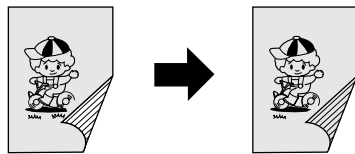

2 → 1 Copy 2-Sided → 1-Sided Copy

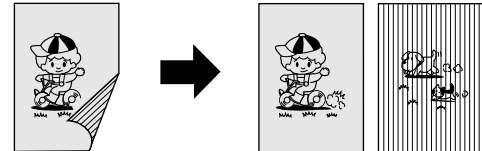

NOTE:

When using the Sheet Bypass, 2→2 Copy function is not available.

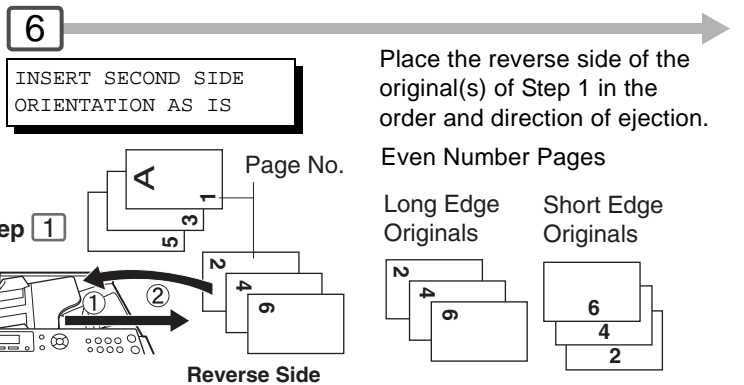
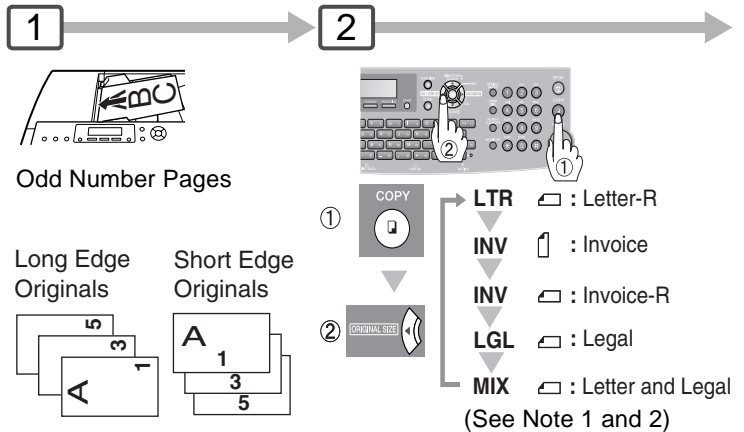

NOTE

1. This function is available only when the optional Tray-2 is installed and both Legal and Letter-R size papers are loaded in Tray-1 and Tray-2 respectively.

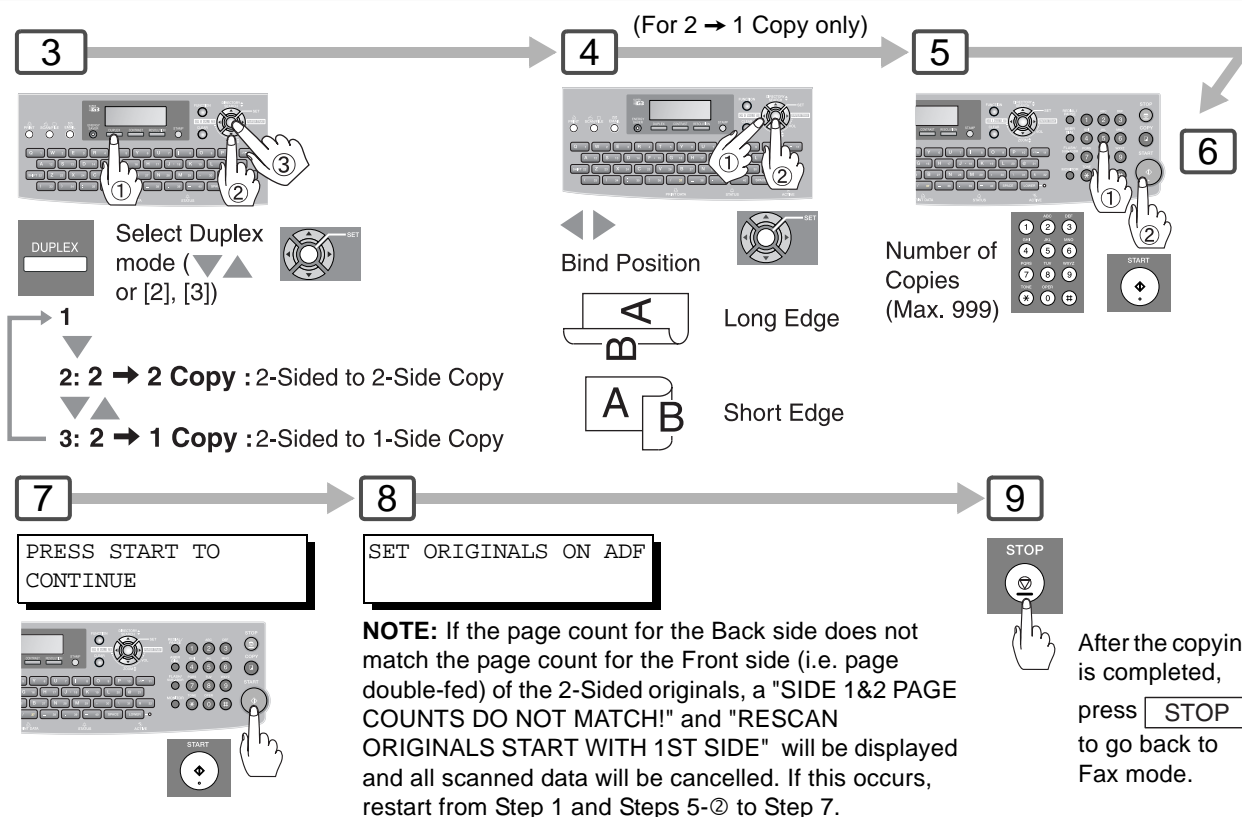
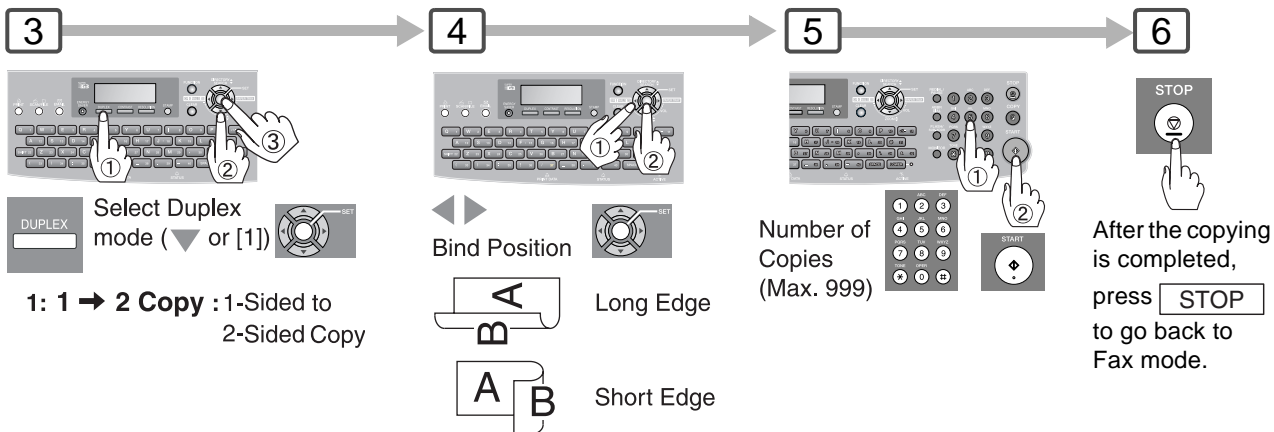

NOTE

2. The default original size is "LETTER". If you use the Multi-Size Feeding function, change the default original size to "MIX" in the Copier Settings for Key Operator, Parameter No. 13 (ORIGINAL SIZE). (See page 117)

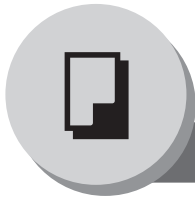

Copy Features

Other Features

■ Changing the Paper Size (Sheet Bypass)

The Sheet Bypass is designed to accommodate B5, A5, A4, FLS1, FLS2, Invoice, Letter, Legal Size paper and Transparency Film.

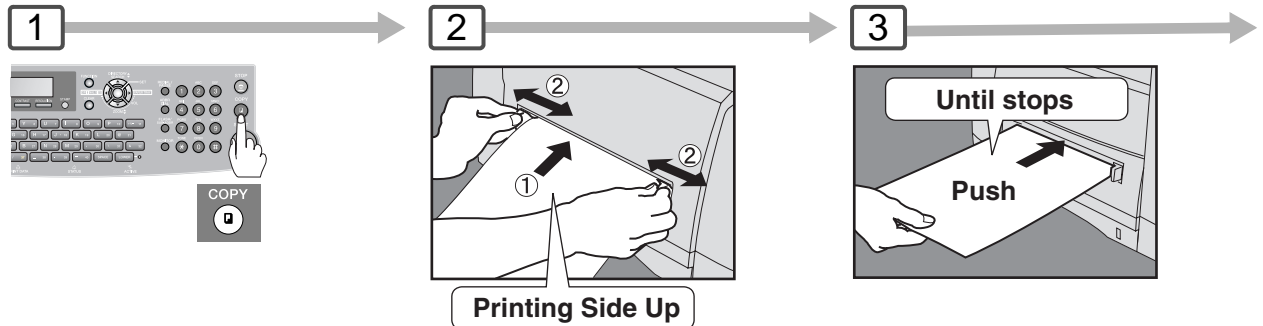

- ① Feed a sheet of paper at a time.
Paper Weight: 16 - 44 lb
- ② Adjust the width guides.
Incorrect adjustment may cause the paper to wrinkle, misfeed or skew.

■ Energy Saver (Power Saver Mode, Sleep/Shutdown Mode)

These modes save power while the machine is not in use. You can select desired save mode and timer in Fax Parameter No.34. (See page 111)

Power Saver Mode

To enter



or

Automatically enters the Power Saver Mode after 10 minutes (default setting) from the last operation.



Flashes :
Power Saver Mode

To Exit



or any keys

Sleep/Shutdown Mode

Automatically enters the Sleep/Shutdown Mode after 10 minutes from the last operation.

NOTE:

To adjust the default Mode timer, See page 111.



Lights :
Sleep/Shutdown Mode

To Exit



Modes	Power Consumption	Warm Up Time
Normal Operation	Approx. 80 W	-
Power Saver	Approx. 12 W	Approx. 19 sec.
Sleep	Approx. 7 W	Approx. 19 sec.
Shutdown	Approx. 1 W	Approx. 19 sec.

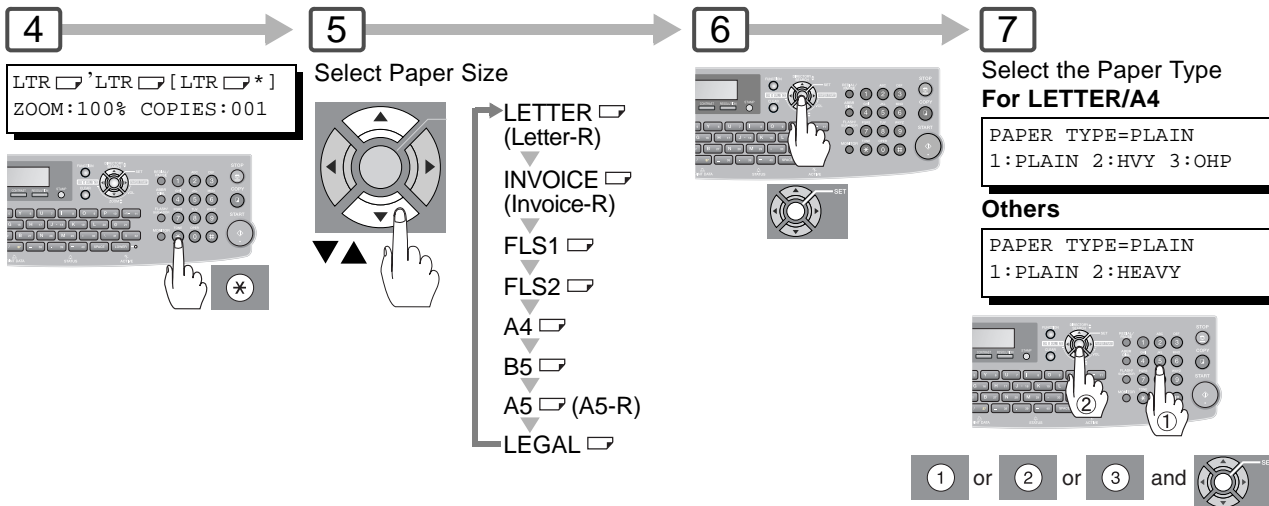

NOTE:
 "3:OHP" selection is displayed only when Letter or A4 paper size is selected.
 (See page 25)



Setting Your Machine

Adjusting the Volume and Dialing Method (Tone or Pulse)

■ Setting the Dialing Method (Tone or Pulse)

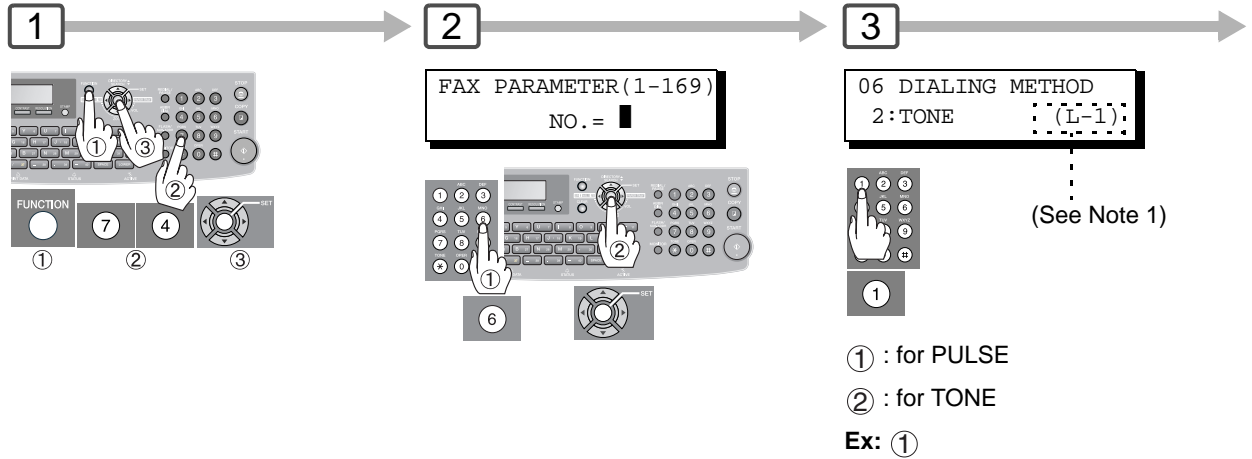

■ Setting the Monitor Volume

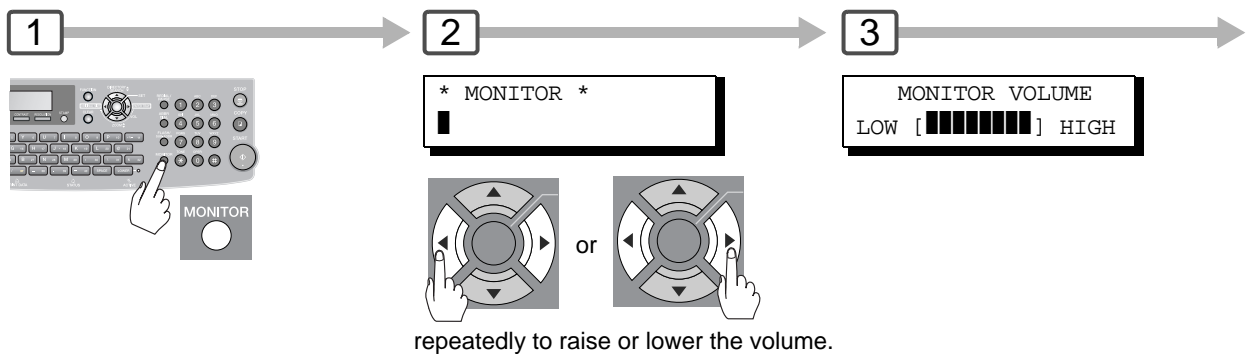

■ Setting the Ringer Volume

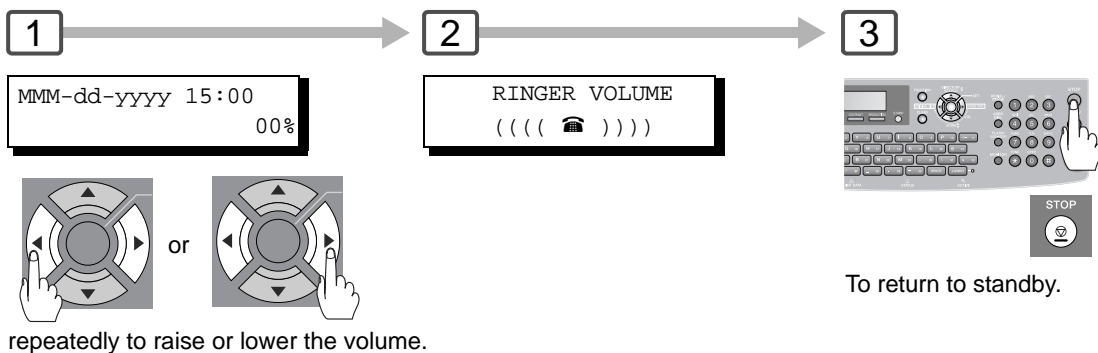

NOTE

1. This message is displayed when optional G3 Communication Port Kit is installed.

4

06 DIALING METHOD
1:PULSE (L-1)

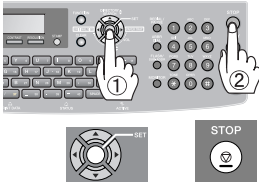

4



To return to standby.



Setting Your Machine

Programming Auto Dialer

■ General Description

Your machine has 2 types of Auto Dialers. The default dialer can be selected by changing the setting of Fax Parameter No. 119 "QWERTY KEYBOARD".

When the setting is set to:

"1: One-Touch" : You can manually select the desired One-Touch Key, ABBR Dialing and the Program Key.

"2: Quick Name Search" : You can select the station by searching the Station Name, and the Program Name.

■ Programming Address Book Dialing

(When Fax Parameter No.119 is set to "2:Quick Name Search", see page 112.)

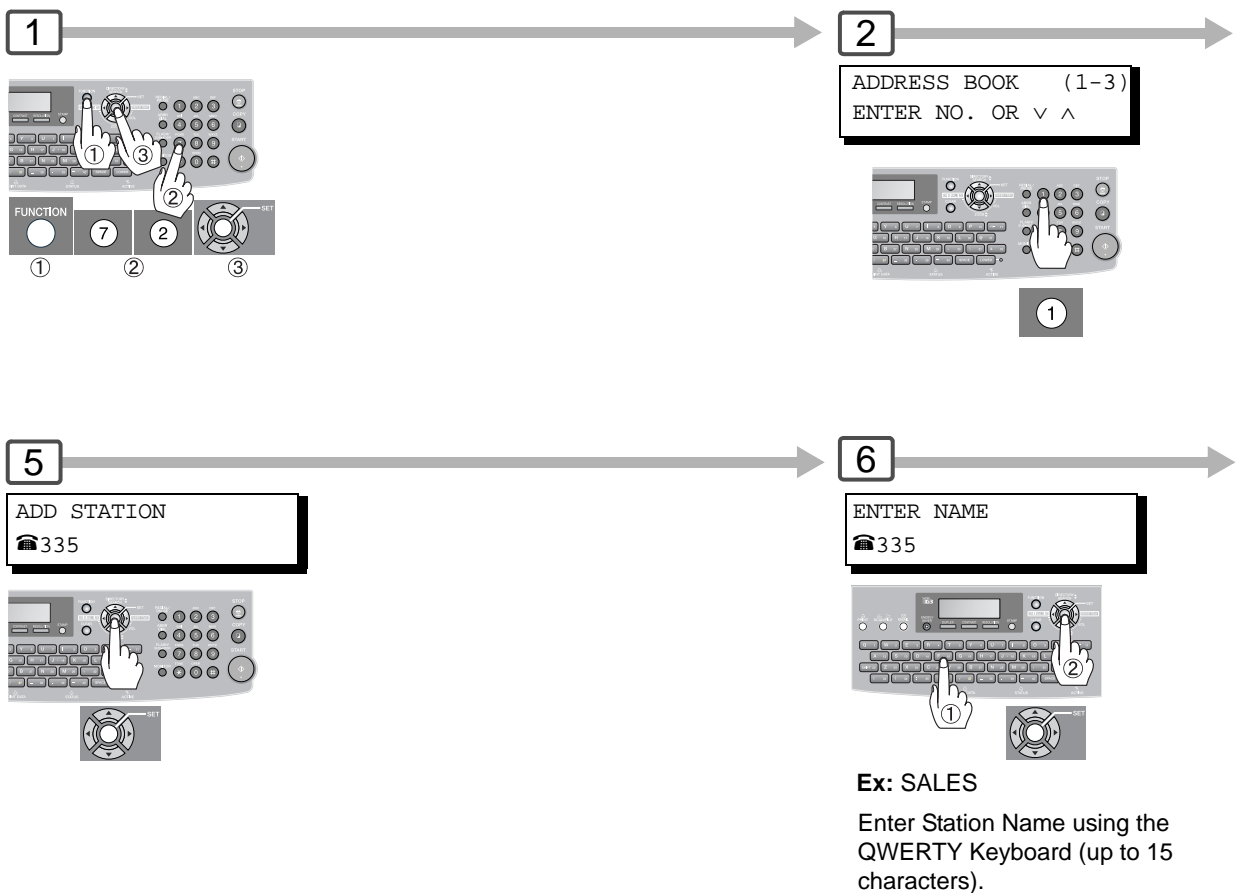

NOTE

1. If you are using Pulse dialing and you wish to change to Tone dialing in the middle of dialing, press **TONE** (represented by a"/"). The dialing method will be changed from Pulse to Tone after dialing the digit "/".
2. When using Address Book Dialing, you cannot use ABBR NUMBER Dialing.

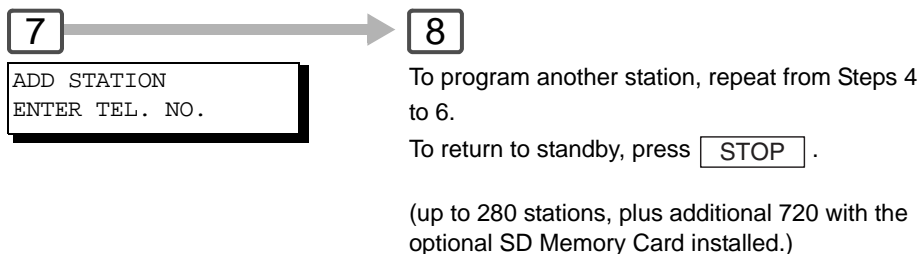
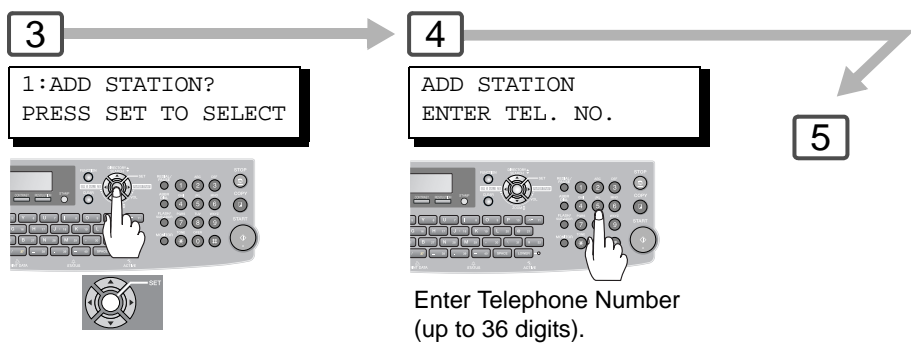



Setting Your Machine

Programming Auto Dialer

■ Entering One-Touch Dialing Numbers

(When Fax Parameter No. 119 is set to "1:One-Touch", see page 112.)

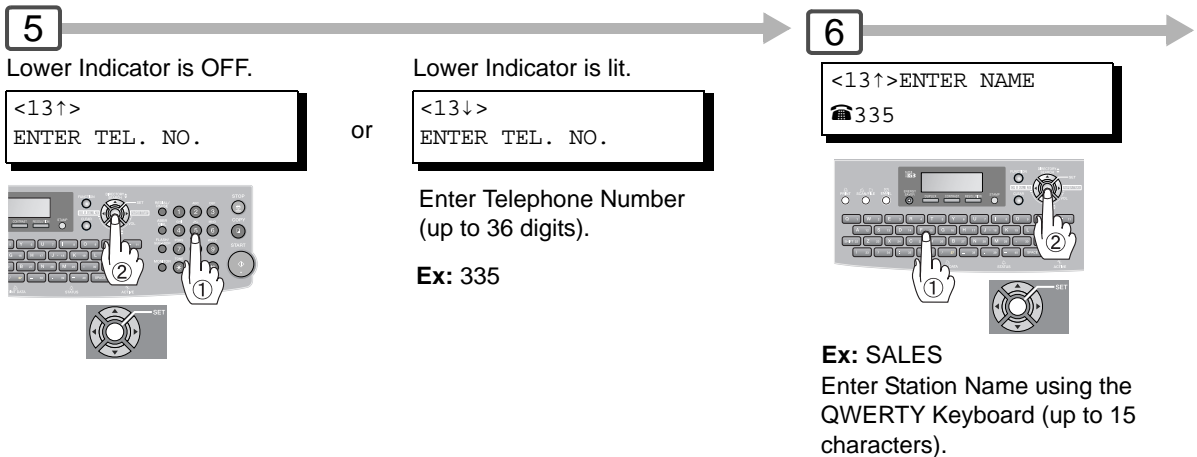
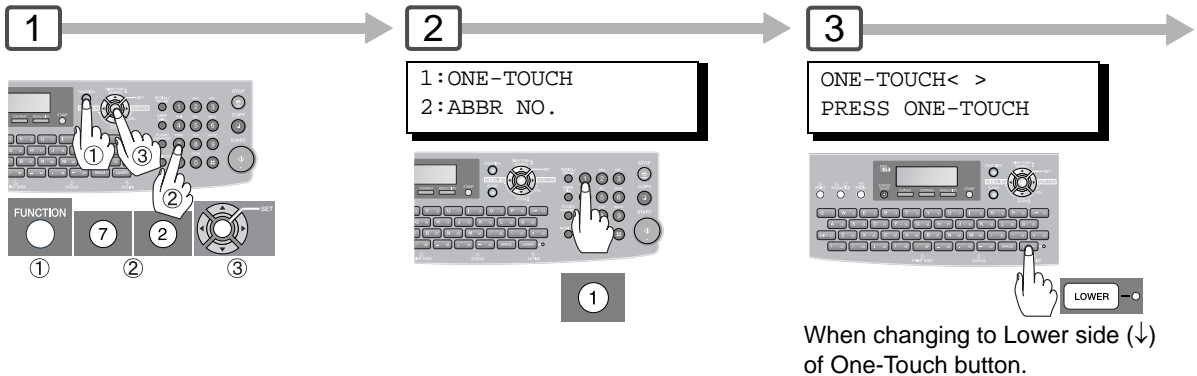

■ Entering Abbreviated Dialing Numbers

(When Fax Parameter No. 119 is set to "1:One-Touch", see page 112.)

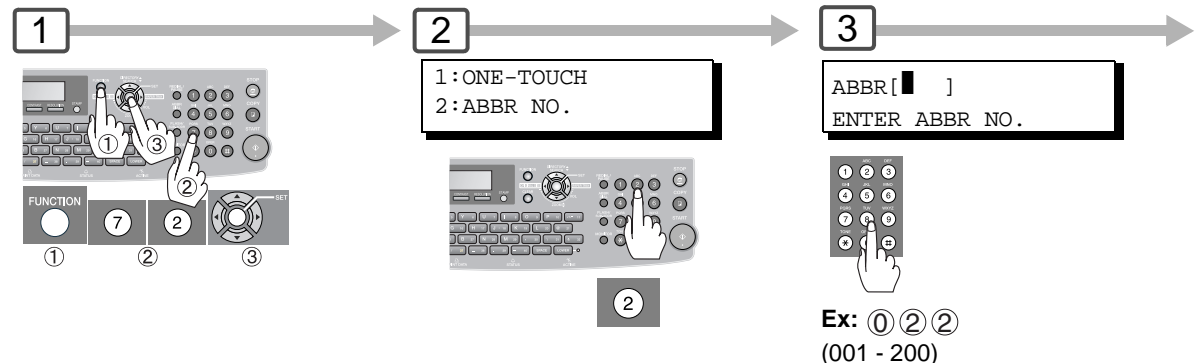

NOTE

1. If you are using Pulse dialing and you wish to change to Tone dialing in the middle of dialing, press **TONE** (represented by "a"). The dialing method will be changed from Pulse to Tone after dialing the digit "a".
2. When using Address Book Dialing, you cannot use Abbreviated Dialing.



Select One-Touch
Ex: 13

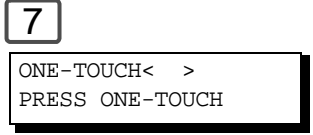

To record another number,
 repeat Steps 3 to 6.
 To return to standby, press
STOP.

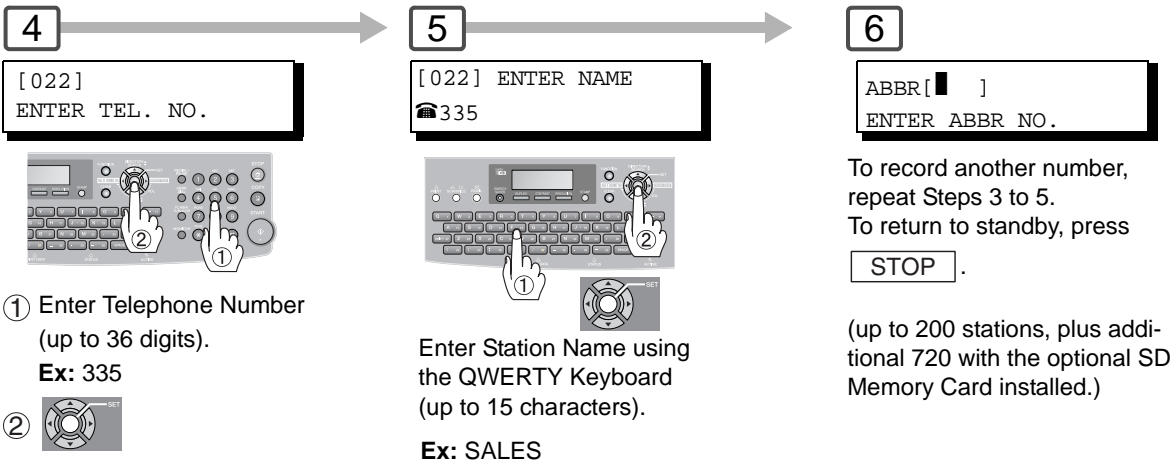

① Enter Telephone Number
 (up to 36 digits).
Ex: 335

②

Enter Station Name using
 the QWERTY Keyboard
 (up to 15 characters).
Ex: SALES

To record another number,
 repeat Steps 3 to 5.
 To return to standby, press
STOP.

(up to 200 stations, plus additional 720 with the optional SD Memory Card installed.)

Directory Sheet Sample

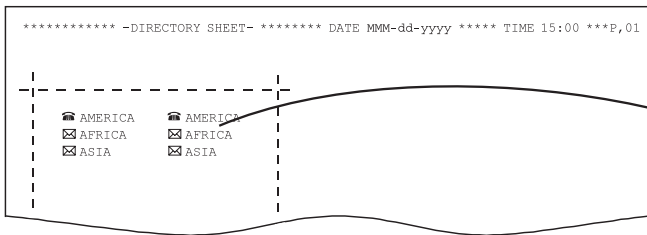

Cut the Directory Sheet along the dashed lines and insert into the Directory Holder.

Note: It may be necessary to trim the edges a bit further for the sheet to fit into the holder better.

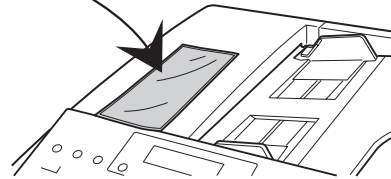

Explanation of Contents

- ☎ : Telephone Number is programmed
- ✉ : Email Address is programmed
- ☎ : Group Dial is programmed
- (None) : Program Key is not programmed



Setting Your Machine

Programming Auto Dialer

■ Address Book Modification

(When Fax Parameter No. 119 is set to "2:Quick Name Search", see page 112.)

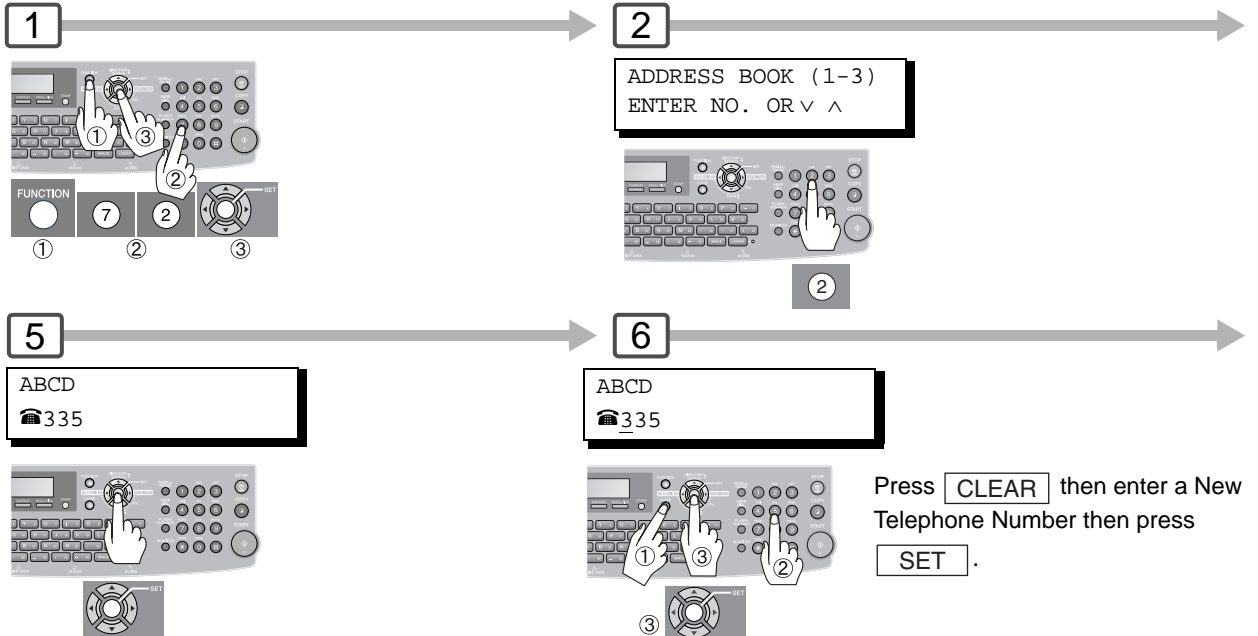

■ Address Book Deletion

(When Fax Parameter No. 119 is set to "2:Quick Name Search", see page 112.)

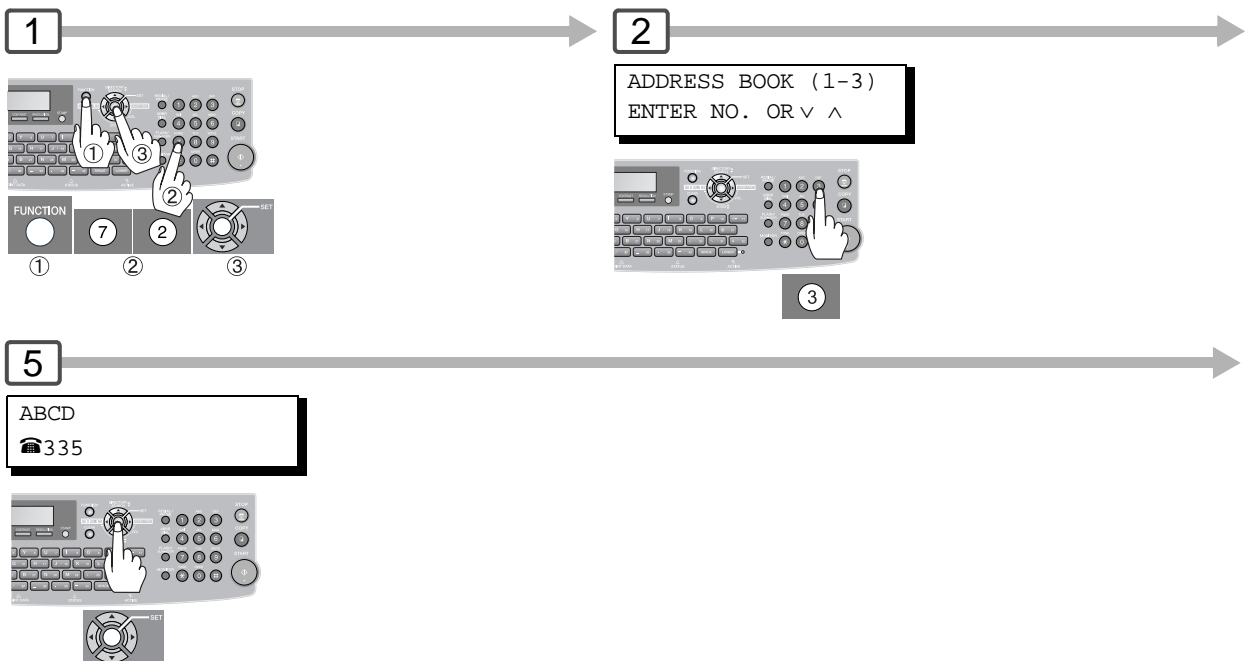

NOTE

1. If you need to dial a prefix to get an outside line, enter it first and then press **PAUSE**. A hyphen "-" is displayed for pause or utilize "Dial Prefix" function to automatically add the prefix (see page 86).
2. Use **MONITOR** to enter a space between the numbers to make it easier to read.

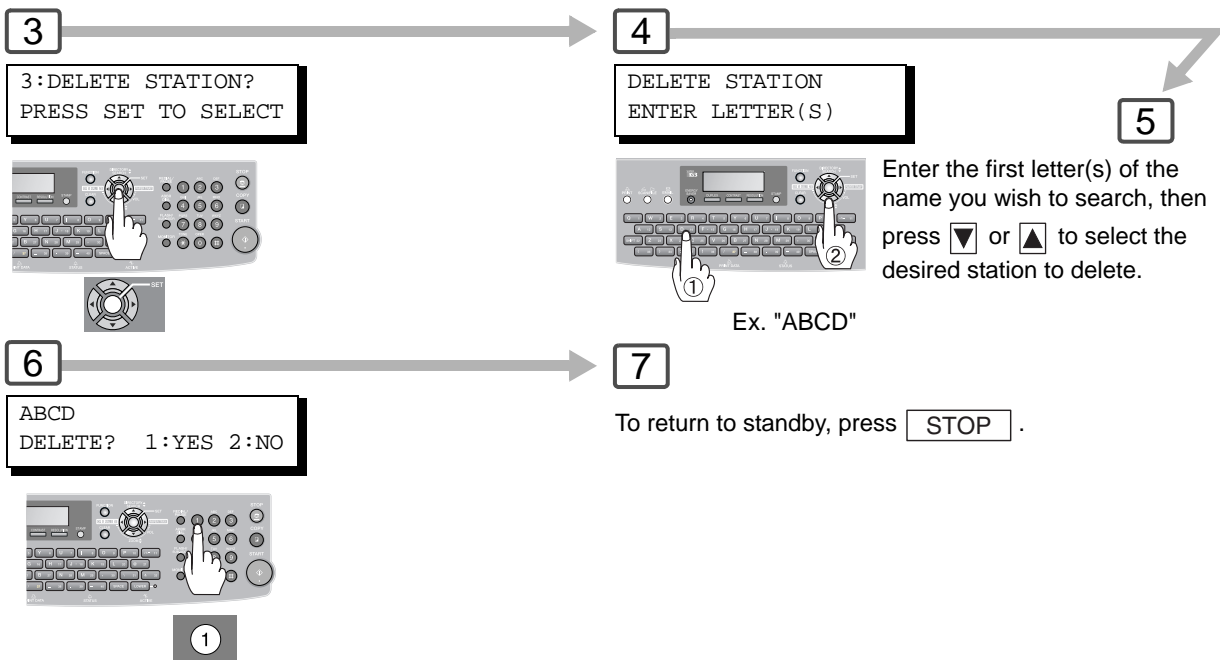
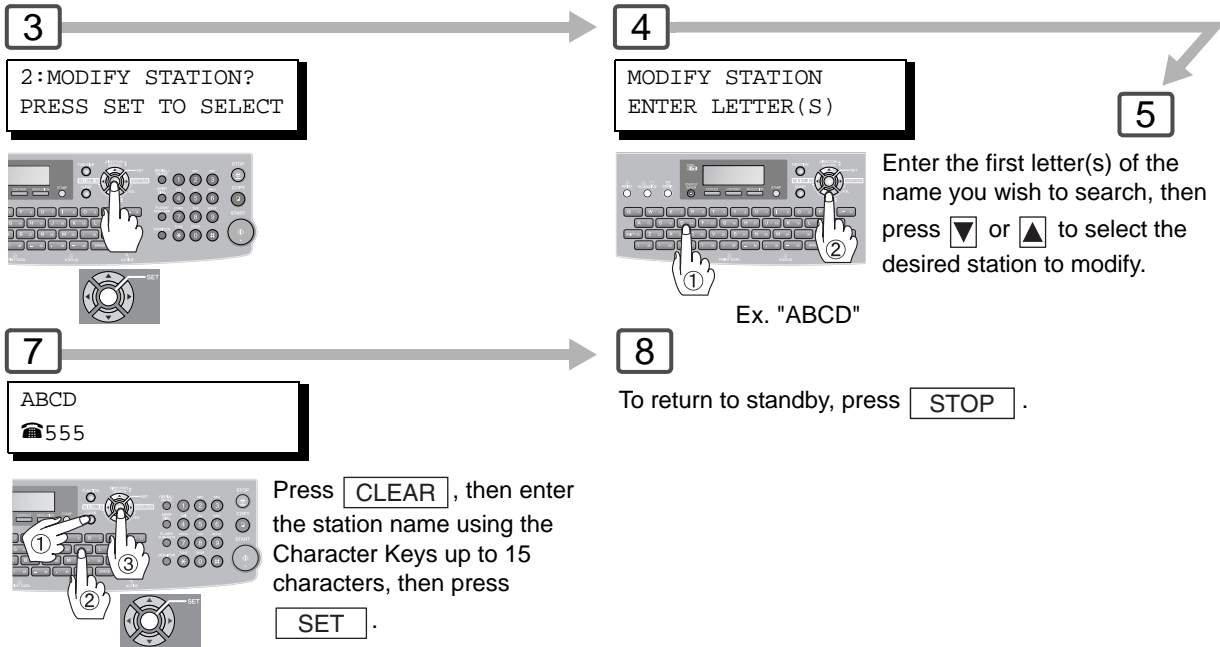

NOTE

3. To correct a mistake, use **[LEFT]** or **[RIGHT]** to move the cursor to the right side of the incorrect number; press **[CLEAR]** then re-enter the correct number.



Setting Your Machine

Programming Auto Dialer

■ Changing or Erasing the Settings of the One-Touch/Abbreviated Dialing Numbers

(When Fax Parameter No. 119 is set to "1:One-Touch", see page 112.)

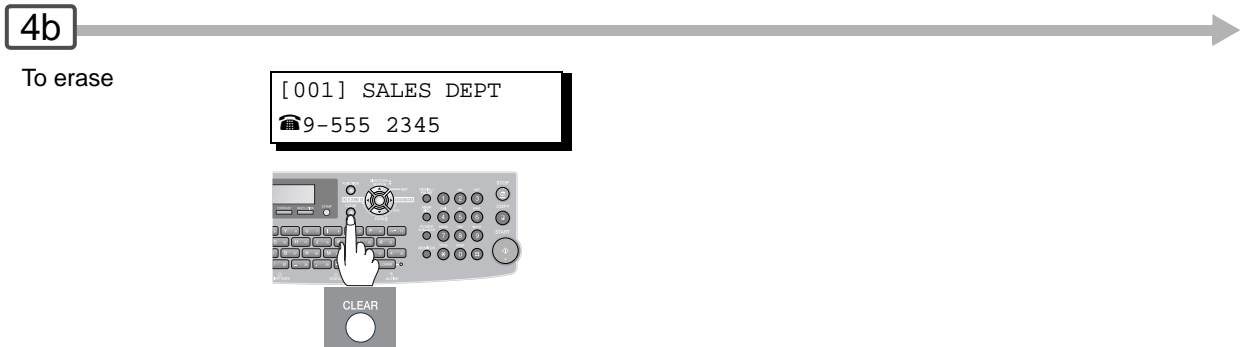
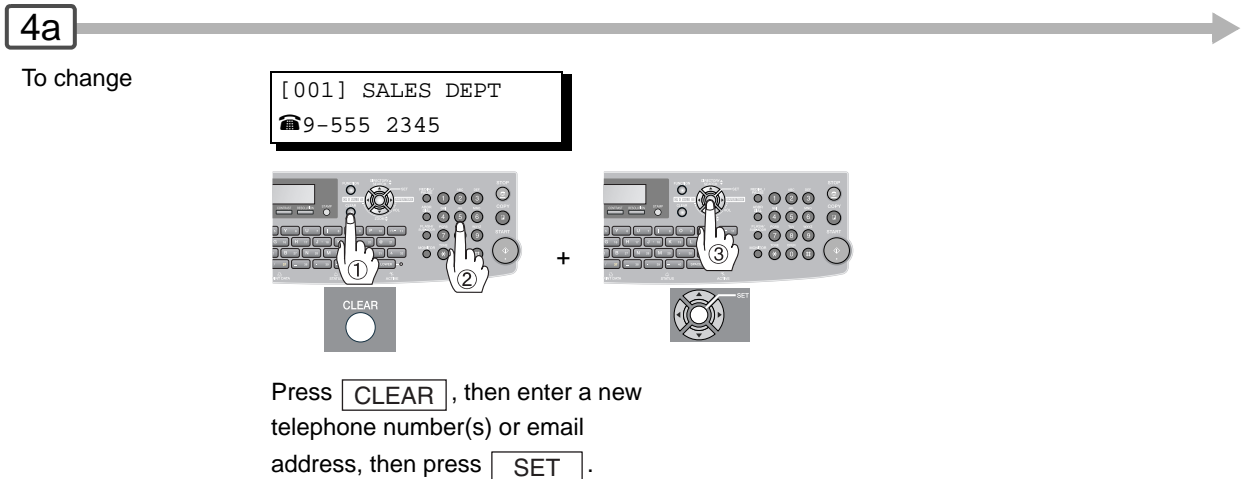
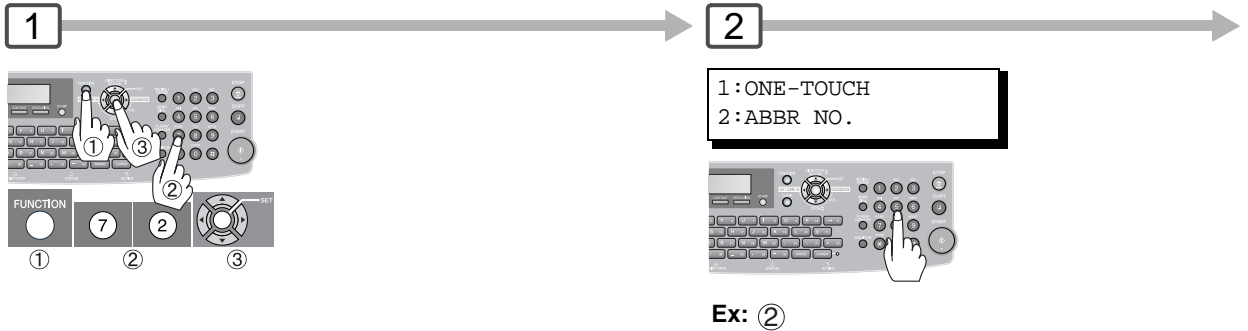

NOTE

1. If you need to dial a prefix to get an outside line, enter it first and then press **PAUSE**. A hyphen "-" is displayed for pause.
2. Use **MONITOR** to enter a space between the numbers to make it easier to read.
3. If you have to change any of the One-Touch/ABBR. No., enter a new number, email address or station name after pressing **CLEAR** key in each Steps.
4. To correct a mistake, use **◀** or **▶** to move the cursor to the right side of the incorrect number; press **CLEAR** then re-enter the correct number.

3

ABBR []
 ENTER ABBR NO.





4a To change
or
4b To erase

Ex: ① ① ①

5a → **6a**

[001] SALES DEPT
 ☎9-555 3456

+ 

ABBR []
 ENTER ABBR NO.

To return to standby.

Press **CLEAR**, then enter the station name using the QWERTY Keyboard (up to 15 characters), then press **SET**.

Ex: ABCD

5b → **6b**

[001] SALES DEPT
 ENTER TEL. NO.



Press **SET**.



To return to standby.

NOTE

5. If the Auto Dialer has been used for a communication reservation, the settings cannot be changed or deleted until the communication has finished. To change or delete the settings, cancel the communication first by using the Edit File Mode. (See page 78)



Setting Your Machine

User Parameters (For Facsimile)

General Description

Your machine has several basic settings (User Parameters) to help you keep records of the documents you send or receive. For example, the built-in clock keeps the current Date and Time, your LOGO and ID Number to help identify you when you send or receive documents.

These parameters can be programmed via your PC by using the Configuration Editor included in the Document Management System CD with the machine.

Follow the Operating Instructions included in the Document Management System CD.

Setting the User Parameters

1 → **2** → **3**

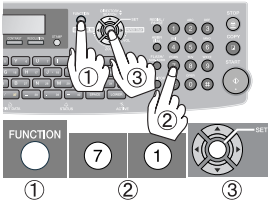
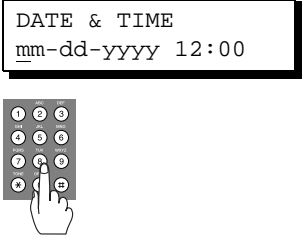
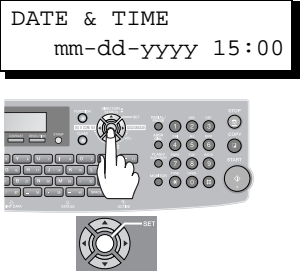
Enter the new Date and Time.
Ex: mm-dd-yyyy 15:00

6 → **7** → **8**



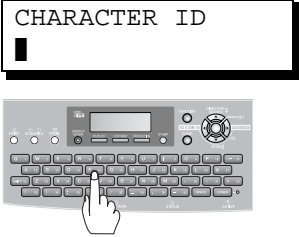
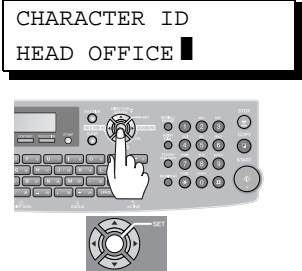
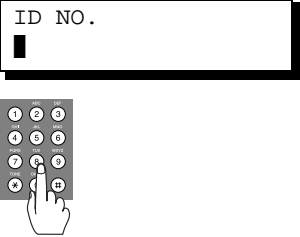

Enter your Character ID (Up to 16 characters and digits)
Ex: HEAD OFFICE

Enter your ID (Up to 20 digits)
(Press to add a space)
Ex: 201 555
 1212

NOTE

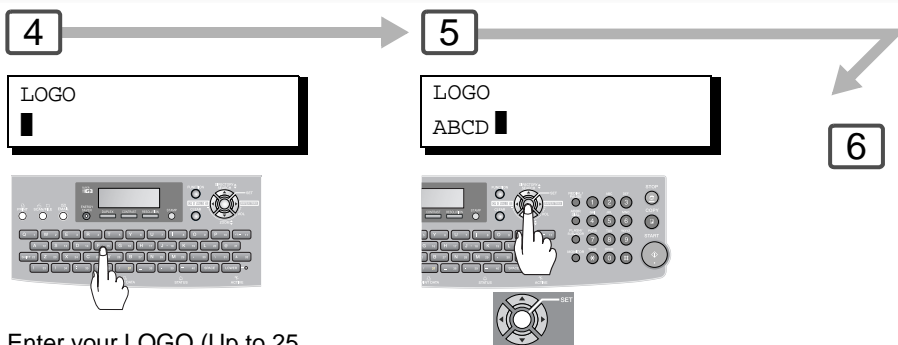
- Special characters, such as Å, Ä, Ö, Ü, Æ, è and é cannot be used for Character ID.
- To correct a mistake, use or to move the cursor to the right side of the incorrect number or character, press then re-enter the correct number or character. If you wish to clear all numbers or characters, press when the cursor is positioned at the beginning of the number or character field.
- The current Date & Time must be set because it is required by the Telephone Consumer Act of 1991. (For details, see FCC NOTICE at the beginning of these Operating Instructions.) (See page 17)
- Your Company Name or your name must be set as your LOGO because it is required by the Telephone Consumer Act of 1991. (For details, see FCC NOTICE at the beginning of these Operating Instructions.) (See page 17)



Enter your LOGO (Up to 25 characters and numbers)
Ex: ABCD

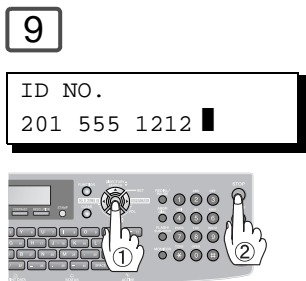

Exits the User Parameter Mode.
 (Programming other User Parameters is not necessary to use the Facsilime Function.)
 To return to standby.

NOTE

5. You may use **TONE** to enter a "+" character at the beginning of the ID number to indicate the following digit(s) for your country code.
Ex: +1 201 555 1212 +1 for U.S.A. country code.
 +81 3 111 2345 +81 for Japan country code.
6. Your Fax Telephone Number must be set as your ID Number because it is required by the Telephone Consumer Act of 1991. (For details, see FCC NOTICE at the beginning of these Operating Instructions.) (See page 17)



Setting Your Machine

Fax Parameters

■ General Description

Your machine has a variety of adjustable Fax Parameters. These parameters, listed in the Parameter Table, are preset for you and do not need to be changed. If you want to make a change, read the table carefully. Some parameters, such as the Resolution and Contrast parameters, can be temporarily changed by simple key operation just before a transmission is made. When the transmission ends, however, these parameters return to their preset values (Home position). Other parameters can only be changed by the procedure described below.

■ Setting the Fax Parameters

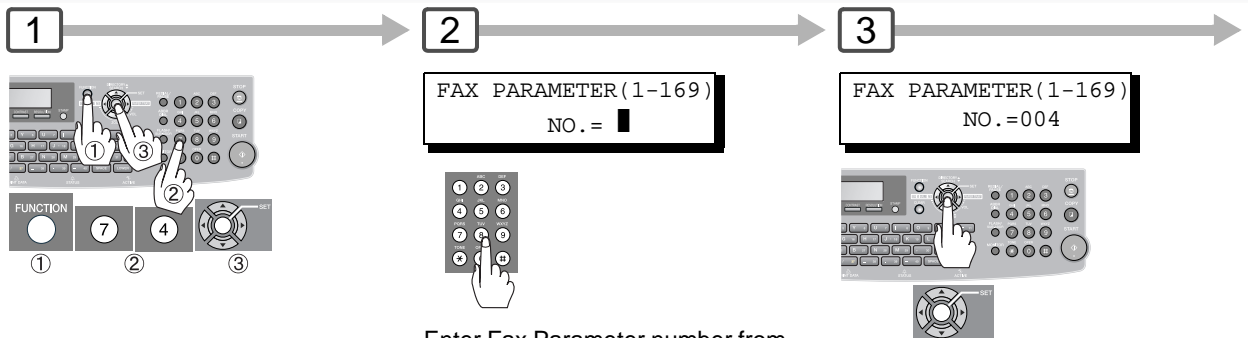

Enter Fax Parameter number from the Parameter Table.

Ex: ①①④

NOTE:

When "Internet Fax/Email/Network Scanner Module" option is installed, the Fax Parameter range extends 1 to 182.

NOTE

1. To scroll the Fax Parameters in Step 2, press ▼ or ▲.
2. To print out a Fax Parameter List, see page 130.

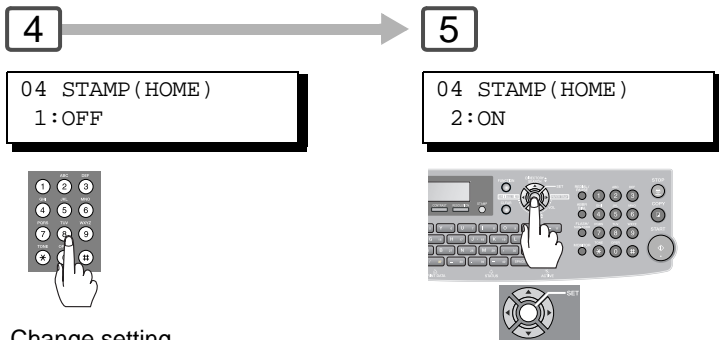

Change setting.

Ex: ② for "ON"

To set another parameter, press

CLEAR to return to Step 3 or press

STOP to return to standby

NOTE

3. Fax Parameter setting mode is accessible only when the machine is in the Ready Mode.



Setting Your Machine

Fax Parameters

Fax Parameter Table

No.	Parameter	Setting Number	Setting	Comments
001	CONTRAST (HOME)	1	Lightest	Setting the home position for the CONTRAST.
		2	Lighter	
		*3	Normal	
		4	Darker	
		5	Darkest	
002	RESOLUTION (HOME)	1	Standard	Setting the home position for the RESOLUTION.
		*2	Fine	
		3	S-Fine	
		4	600dpi	
		5	Halftone (Fine)	
		6	Halftone (S-Fine)	
		7	Halftone (600dpi)	
004	STAMP (HOME)	*1	Off	Setting the home position for the STAMP. To select the stamp function when document is stored in memory, see Fax Parameter No. 28.
		2	On	
005	MEMORY (HOME)	1	Off	Setting the home position for the MEMORY.
		*2	On	
006	DIALING METHOD	1	Pulse	Selecting the dialing method.
		*2	Tone	
007	HEADER PRINT	*1	Inside	Selecting the printing position of the header. Inside : Inside TX copy area. Outside : Outside TX copy area. No print : Header is not printed.
		2	Outside	
		3	No print	
008	HEADER FORMAT	*1	Logo, ID No.	Selecting the header format.
		2	From To	
009	RCV'D TIME PRINT	*1	Invalid	Selecting whether the machine prints the received date & time, remote ID, percentage of reduction and page number on the bottom of each received document.
		2	Valid	
010	KEY/BUZZER VOLUME	1	Off	Selecting the key touch beep sound.
		*2	Soft	
		3	Loud	
012	COMM. JOURNAL	1	Off	Selecting the home position of printout mode for COMM. Journal Off/Always/Inc. only. Off : Does not print Always : Always prints Inc. Only : Prints only when communication has failed.
		2	Always	
		*3	Inc. Only	
013	AUTO JOURNAL PRINT	1	Invalid	Selecting whether the machine prints the journal automatically after every 200 transactions.
		*2	Valid	
014	FILE ACCEPTANCE REPORT	*1	Invalid	Selecting whether the machine prints the file acceptance journal. If you set this parameter to valid, a journal will be printed out after a new job is stored in the memory.
		2	Valid	
017	RECEIVE MODE	1	Manual	Setting the reception mode to automatic or manual.
		*2	Auto	

No.	Parameter	Setting Number	Setting	Comments
022	SUBSTITUTE RECEIVE	1	Invalid	Selecting whether the machine receives to memory when the recording paper runs out, toner runs out or the recording paper is jammed.
		*2	Valid	
023	REC. PAPER SIZE		(----	Selecting the Paper Tray and paper size. (See page 118)
024	PRINT REDUCTION	1	Fixed	Selecting print reduction mode.
		*2	Auto	Fixed : Reduce received document according to setting of Parameter No. 25. Auto : Reduce received document according to the length of received documents.
025	REDUCTION RATIO	70	70%	Selecting the fixed print reduction ratio from 70% to 100%. This parameter functions only when the fixed print reduction is selected on Fax Parameter No. 24.
		----	----	
		*100	100%	
026	POLLING PASSWORD		(----	Setting a 4-digit password for secured polling.
027	POLLED FILE SAVE	*1	Invalid	Selecting whether the machine retains the polled document in memory even after the document is polled once.
		2	Valid	
028	STAMP AT MEMORY XMT	1	Invalid	Selecting whether the machine stamps the original documents when storing the documents into memory. (depending on the Stamp setting on the Control Panel. If the setting is "Invalid", the machine will not stamp even if the Stamp LED light is ON)
		*2	Valid	
031	INCOMPLETE FILE SAVE	*1	Invalid	Selecting whether the machine retains the document in memory if the document is not successfully transmitted.
		2	Valid	
034	ENERGY SAVER MODE	1	Invalid	Select a Energy Saver mode and time. 1 : Invalid / 2 : Power Saver / 3 : Sleep / 4 : Shutdown Mode timer : 1-240 min.
		2	Power Save	
		*3	Sleep	
		4	Shutdown	
035	DAYLIGHT TIME	1	Invalid	Selects whether to enable the daylight time feature.
		*2	Valid	
036	RING PATTERN DETECT (DRD) (See page 115, Note 2)	*1	Invalid	All ring patterns.
		2	Valid	Select a ring pattern for automatic answering. 1 : A Standard ring pattern. 2 : B Double ring pattern. 3 : C Triple ring pattern (Short-Short-Long). 4 : D All other triple ring patterns, except the type C described above.
037	RECEIVE TO MEMORY		(----	Enter a 4-digit password used to print out the received document in memory by using F8-5 (RCV TO MEMORY). When F8-5 is set to On, this parameter will not be shown on the LCD display. If you wish to change the password, F8-5 is set to Off first.
038	ACCESS CODE		(----	Enter a 4-digit Access Code to secure the machine from unauthorized use. (See page 84)
039	PIN CODE ACCESS	*1	None	Selecting the access method (Prefix or Suffix) to dial a number with PIN Code.
		2	Suffix	
		3	Prefix	
052	DIAGNOSTIC PASSWORD		(----	Setting the password for Remote Diagnostic Mode. Please ask your Authorized Dealer for details.



Setting Your Machine

Fax Parameters

No.	Parameter	Setting Number	Setting	Comments
053	SUB ADDRESS PASSWORD		(----	Setting a password (up to 20 digits) for secured sub-address communication.
054	FAX FORWARD	*1	Invalid	Selecting whether the machine performs Fax Forwarding to the specified destination.
		2	Valid	
056	COVER SHEET	*1	Off	Setting the home position of the Cover Sheet parameter in the Select Mode. (See page 64)
		2	On	
058	LANGUAGE	*1	A-ENGLISH	Selects the default message language for the display.
		2	C-FRENCH	
		3	SPANISH	
077	DEPARTMENT CODE	*1	Invalid	Selecting whether the machine performs the Department Code operation.
		2	Valid	
082	QUICK MEMORY XMT	1	Invalid	Selecting whether the machine performs Quick Memory Transmission. Invalid : Stores all documents into memory first before dialing the telephone number. Valid : Starts dialing the telephone number immediately after storing the first page.
		*2	Valid	
088	LINE SELECTION	*1	Auto	Selecting the transmitting telephone line when the optional G3 Communication Port Kit is installed. Auto : Selects the available telephone line for transmission automatically. Line-1 : Selects Line-1 as the only transmitting telephone line. Line-2 : Selects Line-2 as the only transmitting telephone line. Note: Regardless of the setting selection above, the unit will answer and receive on both telephone lines.
		2	Line-1	
		3	Line-2	
095	DUPLEX PRINT	*1	Invalid	Selecting whether the machine performs duplex print when receiving the document via G3 Fax or Internet Fax.
		2	Valid	
097	SPECIAL TRAY No.1 - 2	*1	None	Select a Special Tray that will not be used for printing received faxes (Tray 1 or 2). One Tray must always be available for receiving faxes. This setting is available when the optional 2nd Paper Feed Module is installed.
		2	Tray 1	
		3	Tray 2	
099	MEMORY SIZE (SD Memory Card)	-	-	Displays the amount of memory size.
118	FAX FUNCTION DETECT	1	Invalid	Setting the number of digits required to determine the entered number is a Fax Telephone number. Upon detecting the specified number of digits, the machine will automatically switch to the FAX Mode when it is in the Copier Mode.
		2	4-Digit	
		3	5-Digit	
		*4	6-Digit	
		5	7-Digit	
		6	8-Digit	
119	QWERTY KEYBOARD	1	One-Touch	Selecting whether the QWERTY Keyboard functions as a One-Touch Dialing Keys or as Quick Name Search Keys of the station name. One-Touch : Each key(1~40) is assigned with an Email Address or a Telephone Number for quick dialing. Quick Name Search : Entering the first letter of the station name for quick name search of the programmed station and quick dialing.
		*2	Quick Name Search	

No.	Parameter	Setting Number	Setting	Comments
121	AUTO RESET TIMER	1	OFF	Selecting whether the control panel reset time.
		2	30 sec.	
		*3	1 min.	
		4	2 min.	
		5	3 min.	
		6	4 min.	
122	DIAL PREFIX		(----	Setting the Dial Prefix number (Max. 4-digits). When the machine detects a 10-digit telephone number (excluding any characters; such as "-") being dialed, it will automatically append the preset Dial Prefix number. When the telephone number is Less or More than 10-digits in length, the Dial Prefix number is not appended.
140	LAN RELAY XMT REQUEST	*1	Invalid	Selecting whether the machine performs LAN Relay XMT Request.
		2	Valid	
142	RELAY XMT	1	Invalid	Selecting whether the machine accepts and performs G3 relayed transmission. (Relay Station Functions)
		*2	Valid	
143	RELAY XMT REPORT	1	Off	Setting how the COMM. Journal for relayed transmission is sent to the originator. Off : Don't send. Always : Always send. Inc. Only : Send only if communication has failed.
		*2	Always	
		3	Inc. Only	
144	EMAIL CHARACTER SET	1	Japanese	Selecting the Character Set when receiving or sending email text.
		*2	English	
145	SENDER SELECTION	*1	Invalid	Selecting a pre-programmed sender's name and email address before each transmission.
		2	Valid	
146	POP TIMER	----	0 to 60 min.	Setting the time interval for the machine to check for email on the POP Server. (0 = Does not check the POP Server for email.)
		*3		
147	AUTO POP RCV	1	Invalid	Selecting whether the machine automatically downloads an email from the POP Server.
		*2	Valid	
148	DELETE POP RCV EMAIL	1	Invalid	Selecting whether the email will be deleted automatically after retrieval from the POP Server.
		*2	Valid	
149	DELETE POP ERROR EMAIL	*1	Invalid	Selecting whether to delete the email that includes an incompatible file attachment from the POP Server.
		2	Valid	
150	IFAX RETURN RECEIPT	1	Invalid	Selecting whether to send a return receipt when receiving from another Internet Fax.
		*2	Valid	
151	EMAIL HEADER FORMAT	1	All	Selecting the header information to print when an email is received. (Normally used for Troubleshooting. It shows the path of the email transmission before arriving at your machine.)
		*2	Subject/ From/To	
		3	Off	
152	SUB-ADDRESS ROUTING	*1	Invalid	Selecting whether to automatically route a received email using ITU-T sub-address.
		2	Valid	
153	TSI ROUTING	*1	Invalid	Selecting whether to route a received fax to an email address preprogrammed in Phone Book using the originating fax's Numeric ID (TSI frame information).
		2	Valid	



Setting Your Machine

Fax Parameters

No.	Parameter	Setting Number	Setting	Comments
154	ROUTING HEADER FORMAT	*1	Originator	Selecting the type of email header to be included in the "From" field of each routed faxes. Originator :The originating fax machine's TSI will appear in the "From" field of the routed email. Relay Station :The routing station's email address will appear in the "From" field of the routed email.
		2	Relay Station	
155	PRINT ROUTED DOCUMENT	*1	Inc. Only	Selecting whether a received fax to be routed is always printed or only when the routing operation fails.
		2	Always	
156	PRINT FORWARDED DOCUMENT	*1	Inc. Only	Selecting whether a memory received fax or email to be forwarded is always printed or only when forwarding is incomplete.
		2	Always	
157	TRANSACTION JOURNAL	*1	Invalid	Selecting whether the machine sends a transaction journal to the pre-programmed email address.
		2	Valid	
158	PC REMOTE UPDATE	*1	Invalid	Selecting whether the machine will accept commands from an email application, to: (a) Program the Internet Parameters (b) Program the Auto Dialer (c) Allow retrieval of the Journal
		2	Valid	
159	SUBJECT LINE ENTRY	*1	Invalid	Selecting whether the "Subject" line can be programmed during each transmission.
		2	Valid	
160	DEFAULT DOMAIN	1	Invalid	Selecting whether the machine accepts to insert the Default Domain when entering Manual Number Dialing.
		*2	Valid	
161	DNS SERVER	1	Invalid	Selecting whether to use the DNS Server for the Internet communication.
		*2	Valid	
162	TIFF VIEWER URL	1	None	Selecting whether to include the URL address in the email message body.
		*2	English	
		3	English+ Japanese	
163	ROUTING HEADER	*1	Invalid	Selecting whether to add the Header Print information of the Routing Station on the top edge of each routed pages.
		2	Valid	
164	IFAX XMT HEADER (Email only)	*1	Included	Selecting whether to include the header when sending a document to an addressee in the same Domain as specified in the Default Domain parameter. (This is useful when using the machine to scan documents back to your PC) Note: When sending to a Domain other than as specified in the Default Domain parameter, the header will be included regardless of the selection.
		2	Not included	
168	CC/BCC STATION	*1	Invalid	Selecting whether to allow the CC/BCC email address(es) to be entered.
		2	Valid	
169	DHCP CLIENT	1	Invalid	Select whether the machine would automatically acquire the Network Parameters from the DHCP Server. (Such as IP Address, Subnet Mask, Default Gateway IP Address, etc.) Note: If you change the setting of this parameter, the machine will reboot automatically.
		*2	Valid	

No.	Parameter	Setting Number	Setting	Comments
170	SMTP AUTHENTICATION (See page 115, Note 3)	*1	Invalid	If you transmit to the SMTP server, user name and password are used for authentication. Selecting "Valid" allows you to set up the user name and password.
		2	Valid	
171	POP BEFORE SMTP (See page 115, Note 3)	*1	Invalid	If you transmit to the SMTP server, POP user name and POP password are used for authentication.
		2	Valid	
172	DIRECT IFAX XMT	*1	Invalid	Selecting whether to be prompted during Phone Book registration if the station you are programming is to receive Internet Fax directly without going through a Mail Server.
		2	Valid	
173	DELIVERY NOTICE (HOME)	*1	Off	Setting the home position of whether to request a Message Disposition Notification (MDN) for a delivery processing confirmation indicating that the message (email) was read, when sending an email/Internet Fax. This setting will be the default value for the Function Select Mode (F8-2).
		2	On	
174	APOP AUTHENTICATION (See Note 3)	*1	Invalid	This parameter allows you to encrypt the protocol for the POP password security when connecting with the POP server.
		2	Valid	
177	XMT FILE TYPE	1	TIFF	Selecting whether the document(s) are converted to TIFF-F or PDF format when Scanning-to-Email, or TIFF-F format when sending to an Internet Fax. The default is "PDF" as PDF has become the industry standard for exchanging documents from computer to computer (Scan-to-Email). However, neither PDF format can be used for Internet Faxing (Internet Fax to Internet Fax) as current Internet Fax specifications do not support these file formats, and TIFF-F format must be used when sending to an Internet Fax machine. (This setting can be temporarily changed when sending an Internet Fax with the Select Mode (F8-6) "XMT FILE TYPE/NAME")
		*2	PDF	
182	SEND COMM. JOURNAL	*1	Print	Selecting whether the Communication Journal is printed, emailed or both. Print : Prints Email : Emails to the address selected in the Sender Selection. Both : Prints and Emails.
		2	Email	
		3	Both	

NOTE

1. The setting numbers marked with an asterisk (*) indicates the factory standard setting.
2. This parameter supports an optional telephone service "Distinctive Ring Service" provided by your local telephone company. It allows up to 4 different telephone numbers to be assigned on a single telephone line with a distinctive ring for each telephone number. By selecting the appropriate ring pattern associated with the telephone number assigned for your fax machine. It can differentiate and answer the incoming call on the fax number. All other calls on the other telephone numbers will not be answered. This optional service from your local phone company is also called Custom Ringing, Distinctive Ringing, Ident-a-call, Ident-a-ring, Personalized Ringing, RingMaster, RingMate, Selective Ringing, Smart Ring or something similar. Check with your local telephone company on the availability of this service in your area.
3. "Valid" can be selected when the SMTP server or the POP server support these capabilities.



Setting Your Machine

Copier Parameters

Setting the Copier Parameters

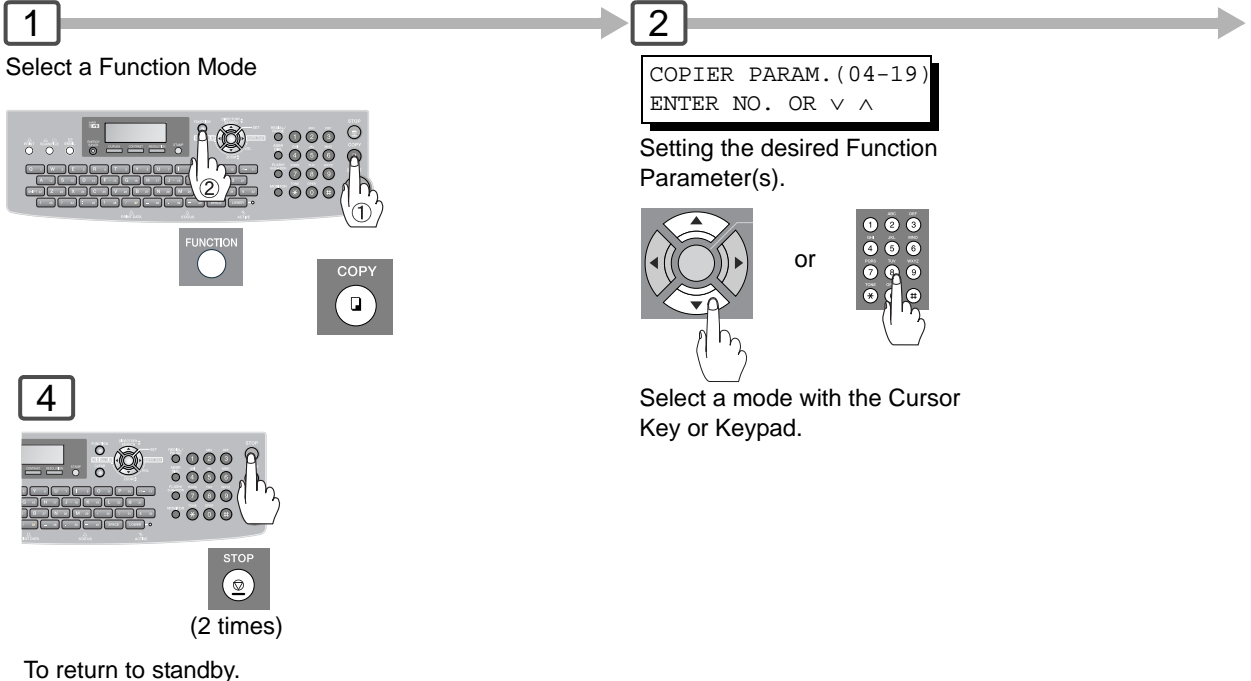

Copier Settings

No.	Modes	Function	Initial Setting
04	2-SIDED MODE DEF.	Selects the default duplex priority mode. 1:OFF / 2:1→2 / 3:2→2	1:OFF
09	AUTO EXPOSURE	Sets the auto exposure setting. 1: INVALID / 2: VALID	2:VALID
10	SORT PRIORITY ADF	Selects the sort priority when using the ADF. 1:NON-SORT / 2:SORT	2:SORT
12	1→2 BINDING DEF.	Selects the binding location for 1→2 Copy. 1:LONG EDGE / 2:SHORT EDGE	1:LONG EDGE
13	2→1 BINDING DEF.	Selects the binding location for 2→1 Copy. 1:LONG EDGE / 2:SHORT EDGE	1:LONG EDGE
19	KEY OPERATOR MODE	Inputs the key operator password. ENTER PASSWORD = ■■■	

NOTE

1. Please refer to the appropriate operating instructions manual for function settings on options.
2. Function setting is accessible only when the machine is in Ready Mode.

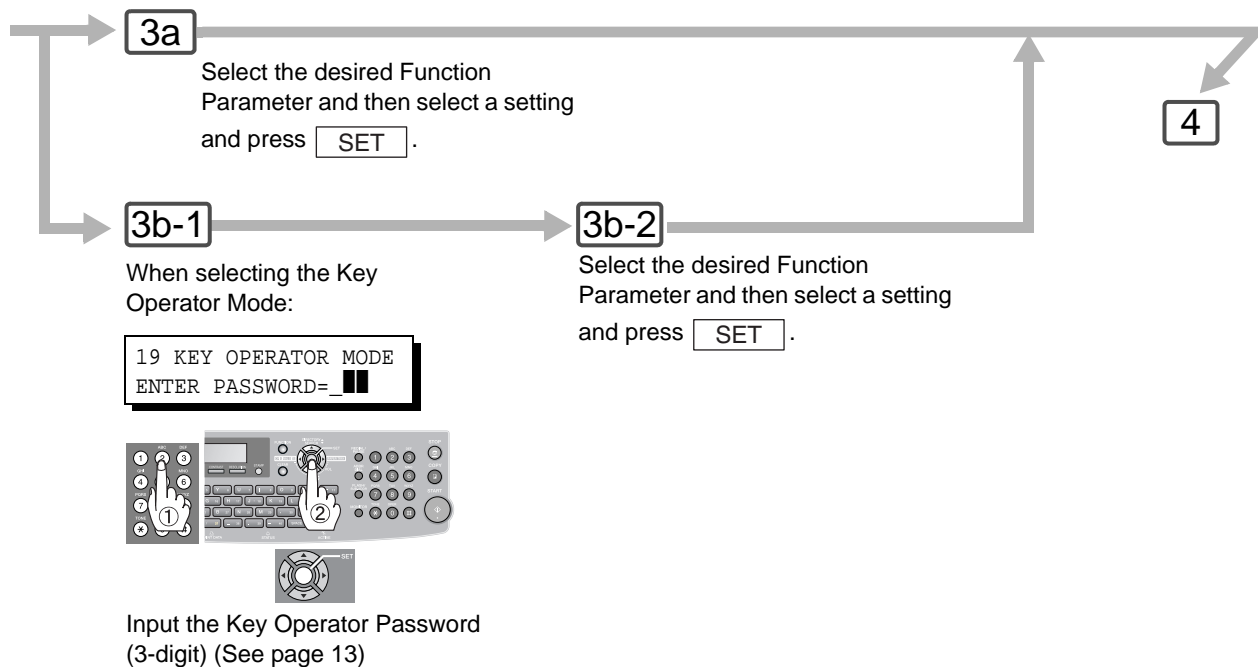

The Following Parameter Settings Require the Input of the Key Operator Password:

■ Copier Settings (For Key Operator)

No.	Modes	Function	Initial Setting
00	COPY SETTING LIST	Prints the copier settings list. PRESS SET TO PRINT	
01	HALFTONE (HOME)	Selects the default Halftone setting. 1:OFF / 2:ON	1:OFF
02	CONTRAST	Selects the contrast setting for the Text mode. 1-5	3
04	HALFTONE CONTRAST	Selects the contrast setting for the Photo mode. 1-5	3
05	MAX. COPY SETTING	Determines the maximum number of copies/sets allowed to be copied. 1-999	999
08	MEM. FULL ACTION	Selects the action to take during memory full condition. 1:PRINT / 2:CANCEL	1:PRINT
09	TONER SAVE	Selects the toner save in Text mode. 1:OFF / 2:ON	1:OFF
11	TONER SAVE (HT)	Selects the toner save in Halftone mode. 1:OFF / 2:ON	1:OFF
13	ORIGINAL SIZE	Selects the default original size setting LTR / INV / LGL / MIX (LTR: Letter-R, INV: Invoice, LGL: Legal, MIX: Letter and Legal)	LTR



Setting Your Machine

Changing the Paper Size

■ Changing the Paper Size (Paper Tray)

The Paper Trays are designed to accommodate Letter, A4 and Legal Size paper.

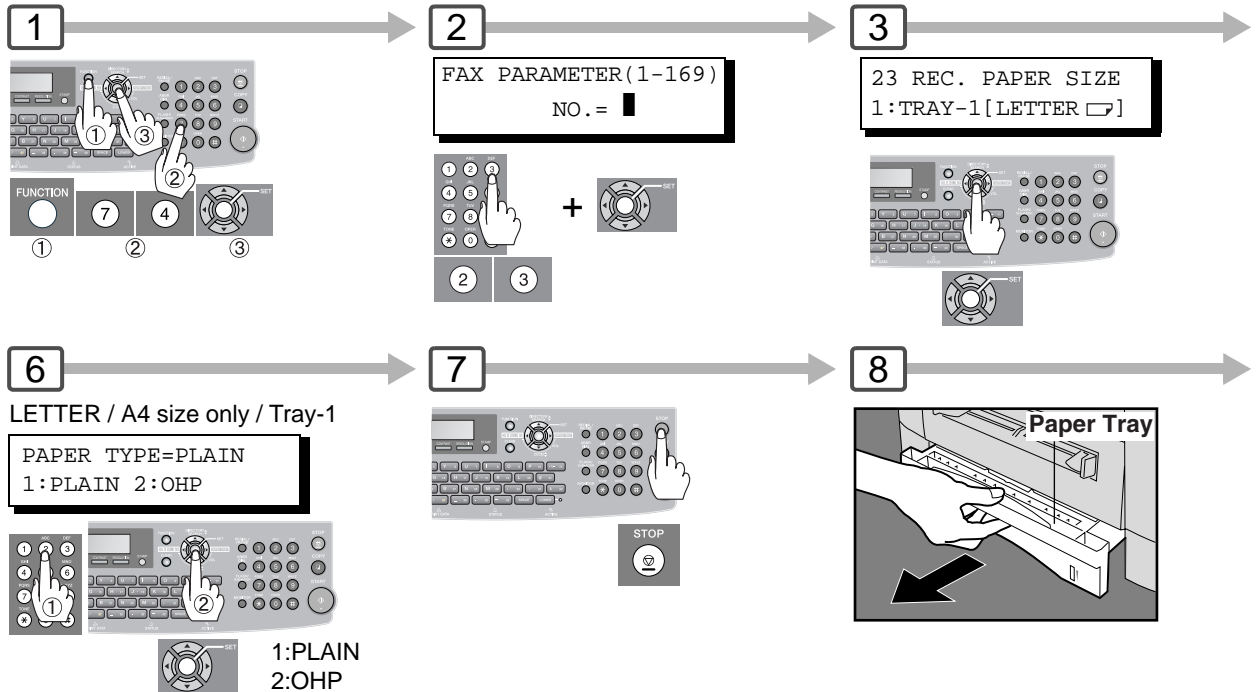

When the optional 2nd Paper Feed Module (TRAY-2) is installed, press the SET Key once and repeat Steps 4 and 5.

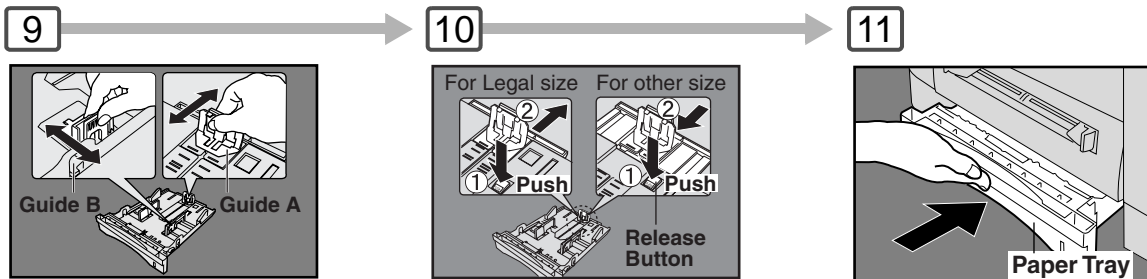
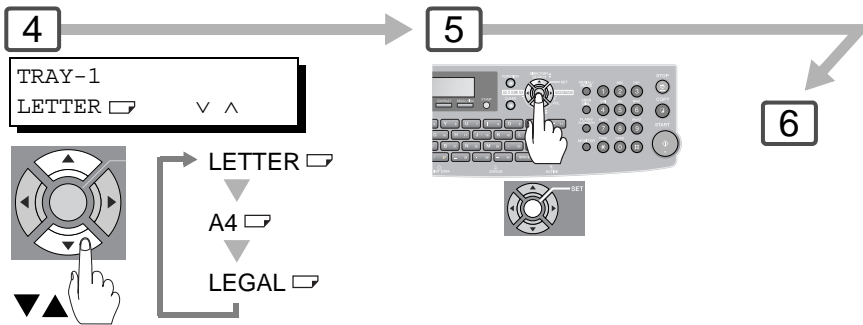

Paper Guide A/B Adjustment

Paper Guide A Length Adjustment



Setting Your Machine

Changing the Original Size

■ Changing the Default Original Size (For Copier)

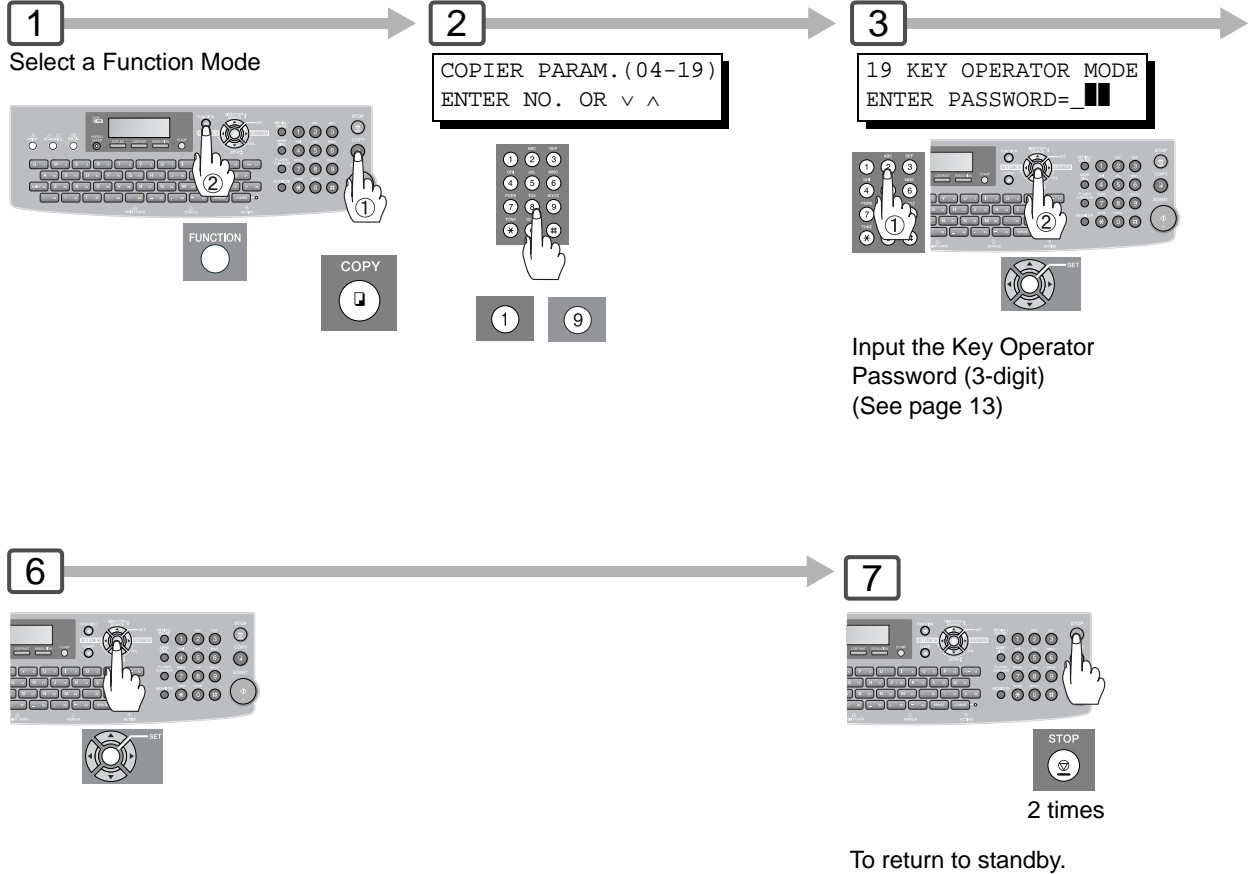

4

KEY OPR. MODE (00-13)
ENTER NO. OR v ^

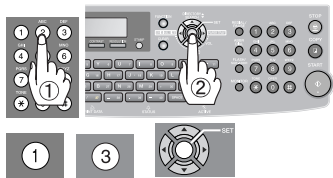

5

ORIGINAL SIZE
LTR v ^

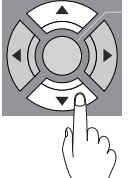

6

- LTR : Letter-R
- INV : Invoice
- INV : Invoice-R
- LGL : Legal
- MIX : Letter and Legal

3a

* PRINTING *
JOURNAL

3b-1

JOURNAL VIEW
1:XMT ONLY 2:ALL

3b-2

USE THE ∨ ^ KEYS TO
SCROLL EACH RECORD

You can view the transactions in the journal by pressing ▼ or ▲. Press

STOP to return to standby.

Ex: ②

Explanation of Contents

- (1) Printout Date : MMM-dd-yyyy, represents the month-day-year.
- (2) Printout Time
- (3) Journal Number
- (4) Communication Result : "OK" indicates that the communication was successful.
"M-OK" indicates that the memory reception was successful.
"BUSY" indicates that the communication has failed because of busy line.
"STOP" indicates that STOP was pressed during communication.
"P-OK" indicates that memory overflow or document misfeeding occurred while storing the documents into memory for transmission, but the successfully stored document(s) was sent.
"R-OK" indicates that the Relayed XMT was successful.
"B-OK" indicates that the Batch Transmission was successful.
"- ." indicates LAN transmission.
"3-digit Info Code (See page 134) indicates that the communication has failed.
- (5) Number of Pages Transmitted or Received : The 3-digit number is the number of pages successfully transmitted or received. When the documents are stored into memory, two 3-digit numbers will appear. The first 3-digit number represents the number of pages successfully transmitted. The second 3-digit number represents the total number of pages that were attempted to be transmitted.
Asterisk "*" indicates that the quality of some received copies may be poor.
- (6) File Number : 001 to 999 (If the document is stored into memory, a file number is assigned for each communication.)
- (7) Duration of Communication
- (8) Type of Communication : "XMT" means Transmission
"RCV" means Reception
"POL" means Polling
"PLD" means Polled
"FWD" means Fax Forward
"RMT" means Remote Diagnostic
- (9) Remote Station Identification : Name : Recorded name in One-Touch or ABBR. Numbers or remote station's Character ID.
☎ number : Dialed telephone number.
Number : Remote station's ID number.
◆ indicates that the Second Telephone Line (Line-2) was used for the communication.
Email address
- (10) Communication Date
- (11) Communication Start Time
- (12) Diagnostic : For service personnel only
- (13) Own LOGO : Up to 25 characters
- (14) Own ID Number : Up to 20 digits
- (15) Own Character ID : Up to 16 characters

NOTE

- 2. An Email transmission sent to multiple locations is recorded as a single transaction on the Journal.



Printing Journals and Lists

Communication Journal (COMM. JOURNAL)

The Communication Journal (COMM. JOURNAL) lets you verify whether the transmission or polling was successful. You may select the printout condition (Off/Always/Incomplete Only) in Fax Parameter No. 12.

Sample COMM. JOURNAL

***** - COMM. JOURNAL - ***** DATE MMM-dd-yyyy **** TIME 15:00 **** p.01

(1) MODE = MEMORY TRANSMISSION (2) START=MMM-dd 14:50 (3) END=MMM-dd 15:00

FILE NO.= 050 (4)

(5) STN NO.	(6) COMM. NO.	(7) ONE-TOUCH/ ABBR NO.	(8) STATION NAME/EMAIL ADDRESS/TELEPHONE NO.	(9) PAGES	(10) DURATION
001	OK	<01↑>	SERVICE DEPT.	001/001	00:01:30
002	OK	<02↑>	SALES DEPT.	001/001	00:01:25
003	407	<03↑>	ACCOUNTING DEPT.	000/001	00:01:45
004	BUSY	☎	021 111 1234	000/001	00:00:00

- ABCD -

***** KM-F1060 ***** - HEAD OFFICE - ***** - 201 555 1212 - *****

THE SLEREXE COMPANY LIMITED
SAPORS LANE - BOOLE - DORSET - BH 25 8 ER
TELEPHONE BOOLE (945 13) 51617 - TELEX 123456

Our Ref. 350/PJC/EAC 18th January, 1972.

Dr. P.N. Cundall,
Mining Surveys Ltd

... variations of print density ...
cause the photocell to generate an analogous electrical video signal.
This signal is used to modulate a carrier, which is transmitted to a
remote destination over a radio or cable communications link.

At the remote terminal, demodulation reconstructs the video
signal, which is used to modulate the density of print produced by a
printing device. This device is scanning in a raster scan synchronised
with that at the transmitting terminal. As a result, a facsimile
copy of the subject document is produced.

Probably you have uses for this facility in your organisation.

Yours sincerely,

Phil.

P.J. CROSS
Group Leader - Facsimile Research

Explanation of Contents

- | | |
|--|---|
| (1) Indication of Communication Mode | |
| (2) Start Time of Communication | |
| (3) End Time of Communication | |
| (4) File Number | 001 to 999 (When the communication is stored into memory, a file number is assigned for each communication.) |
| (5) Station Number | Sequential number of the Stations. |
| (6) Communication Result | "OK" indicates that the communication was successful.
"M-OK" indicates that memory reception was successful.
"BUSY" indicates that the communication has failed because of busy line.
"STOP" indicates that <input type="button" value="STOP"/> was pressed during communication.
"P-OK" indicates that memory overflow occurred while storing the documents into memory for transmission but successfully stored document(s) was sent.
"R-OK" indicates that the Relayed XMT was successful.
"B-OK" indicates that the Batch Transmission was successful.
"- -" indicates LAN transmission.
"3-digit Info Code" (See page 134) indicates that the communication has failed. In this case, the machine will print the attached report with first page of your document as shown on the previous page. |
| (7) One-Touch/Abbreviated Number or % Symbol | % mark indicates dialed by direct number dialing. |
| (8) Recorded Name in the Address Book, Direct Dialing Number, or Email Address | |
| (9) Number of Pages Transmitted or Received | The 3-digit number is the number of pages successfully transmitted or received.
When the documents are stored into memory, two 3-digit numbers will appear.
The first 3-digit number represents the number of pages successfully transmitted.
The second 3-digit number represents the total number of pages that were attempted to be transmitted. |
| (10) Duration of Communication | |



Printing Journals and Lists

One-Touch/Abbreviated and Directory Search List

To print an Address Book List or One-Touch/Abbreviated Number and Directory Search List of the telephone numbers you have stored.

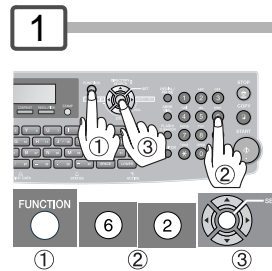

Fax Parameter No. 119:
1:One-Touch

2a

1:ONE-TOUCH/ABBR NO.
2:DIR. SEARCH

- ① : for One-Touch/ABBR. No. List
- ② : for Directory Search List

Fax Parameter No. 119:
2:Quick Name Search

2b

* PRINTING *
ADDRESS BOOK LIST

Sample Address Book List

Email Address and (3), (5) to (7) are not printed when the optional Internet Fax/Email/Network Scanner Module is not installed.

```
***** -ADDRESS BOOK LIST- ***** DATE MMM-dd-yyyy ***** TIME 11:11 *** P.01
(8)  (2)  (3)
      STATION NAME  EMAIL ADDRESS / TELEPHONE NO.
                        ROUTING SUB-ADDR (5)  ROUTING TSI (6)  RELAY ADDR (ABBR NO.) (7)

[B]  Bob Jones    jonesb@abcdefg.com
                        123456                201 555 1212

[J]  John Smith   ☎201 555 3456
                        4452                +1 201 123 4567    [009]

      Jane Smith   ☎201 555 1212
                        1212                212 555 1234      [010]

[K]  Fax1        fax1@company.co.jp
                        4827                +81 03 5251 1234

[M]  Fax2        fax2@company.co.jp
                        1773                +81 0467 5251 1234

      NO. OF STATIONS = 005 (4)

                        -ABCD
***** KM-F1060 *****-HEAD OFFICE - ***** - 201 555 1212- *****
```

- | | |
|---|---|
| (1) One-Touch number or Abbreviated number | <nn>= One-Touch number, [nnn] = Abbreviated number |
| (2) Station name recorded in the machine | : Up to 15 characters |
| (3) Telephone number recorded in the machine | : Up to 36 digits (Telephone number) |
| Email address recorded in the machine | : Up to 60 characters (Email address) |
| %number | : Telephone Number programmed into One-Touch / ABBR NO. |
| (4) Number of recorded One-Touch and ABBR. numbers | |
| (5) Routing Sub-address | : Up to 20 digits |
| (6) Routing TSI | : Up to 20 digits |
| (7) Relay Address | : 3-digit |
| (8) The first letter of station name recorded in your machine | |

3a

* PRINTING *
ONE-TOUCH/ABBR LIST

3b

* PRINTING *
DIR. SEARCH LIST

Sample ABBR. Number List

```
***** -ABBR NO. LIST- ***** DATE MMM-dd-yyyy ***** TIME 11:11 *** P.01
(1) (2) (3)
ABBR STATION NAME EMAIL ADDRESS / TELEPHONE NO. (7)
NO. ROUTING SUB-ADDR (5) ROUTING TSI (6) RELAY ADDR (ABBR NO.)

[001] John Smith 201 555 3456
4452 +1 201 123 4567 [009]

[002] Jane Smith 201 555 1212
1212 212 555 1234 [010]

[003] Bob Jones jonesb@abcdefg.com
123456 201 555 1212

[004] Fax1 fax1@company.co.jp
4827 +81 03 5251 1234

[005] Fax2 fax2@company.co.jp
1773 +81 0467 5251 1234

NO. OF STATION = 005(4)
-ABCD -
***** KM-F1060 *****-HEAD OFFICE - ***** - 201 555 1212- *****
```

Sample One-Touch List

```
***** -ONE-TOUCH LIST- ***** DATE MMM-dd-yyyy ***** TIME 11:11 *** P.01
(1) (2) (3)
ONE- STATION NAME EMAIL ADDRESS / TELEPHONE NO. (7)
TOUCH ROUTING SUB-ADDR (5) ROUTING TSI (6) RELAY ADDR (ABBR NO.)

<01↑> John Smith 201 555 3456
4452 +1 201 123 4567 [001]

<02↑> Jane Smith 201 555 1212
1212 212 555 1234 [002]

<03↑> Bob Jones jonesb@abcdefg.com
123456 201 555 1212

<04↑> Fax1 fax1@company.co.jp
4827 +81 03 5251 1234

<05↑> Fax2 fax2@company.co.jp
1773 +81 0467 5251 1234

NO. OF STATION = 05 (4)
↑ = UPPER (01-40) ↓ = LOWER (01-40) -ABCD -
***** KM-F1060 *****-HEAD OFFICE - ***** - 201 555 1212- *****
```



Printing Journals and Lists

Program List

To print a Program List of the Dialing Patterns that you have previously entered into the Program Keys and One-Touch Dialer.

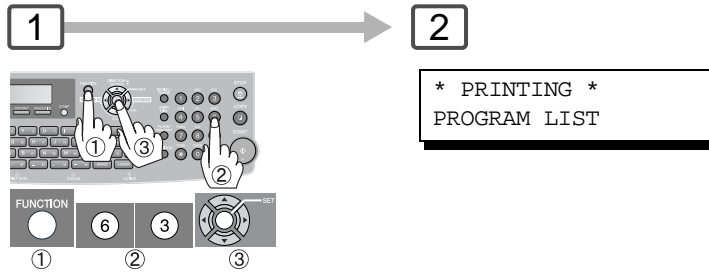

Sample Program List

(When the Fax Parameter No. 119 is set to "2:Quick Name Search".)

```

***** -PROGRAM LIST- ***** DATE MMM-dd-yyyy ***** TIME 15:00 *****
(1)      (2)      (3)      (4)      (5)
PROGRAM  PROGRAM NAME  TYPE      TIMER     DESTINATION(S)
[P]      PROG.A         POLL      ----     [SALES1      ][SALES2      ]
          PROG.B         GROUP     ----     [ABCD1       ][ABCD2       ]

[T]      TIMER POLL    POLL      19:00    [TIMER POLL  ]
          TIMER XMT     XMT       12:00    [TIMER XMT   ]

                                     -ABCD      -

***** KM-F1060 ***** -HEAD OFFICE - ***** -          201 555 1212- *****
  
```

Sample Program List

(When the Fax Parameter No. 119 is set to "1:One-Touch".)

```

***** -PROGRAM LIST- ***** DATE MMM-dd-yyyy ***** TIME 15:00 *****
(1)      (2)      (3)      (4)      (5)
PROGRAM  PROGRAM NAME  TYPE      TIMER     ABBR NOS.
<03↑>   TIMER XMT     XMT       12:00    [001]
<03↓>   TIMER POLL    POLL      19:00    [002]
<05↑>   PROG. A       POLL      ----     [001] [002]
<05↓>   PROG. B       ABBR/GRP  ----     [001] [002] [003]

↑ = UPPER (01-40) ↓ = LOWER (01-40)                                     -ABCD      -

***** KM-F1060 ***** -HEAD OFFICE - ***** -          201 555 1212- *****
  
```

Explanation of Contents

- | | | |
|-----|--|---|
| (1) | The first letter of station name recorded in your machine
Program Key | |
| (2) | Program Name | Up to 15 characters |
| (3) | Type of Communication | "XMT" indicates transmission.
"POLL" indicates polling.
"ABBR/GRP" indicates that the Program key is programmed as a Group or One-Touch key.
"POP" indicates that the Program key is programmed as a POP access key. |
| (4) | Timer | Indicates the starting time.
"----" indicates that the Program key contains "non-deferred" program. |
| (5) | Destination(s)
Numbers Recorded in the Program | One-Touch/ABBR. numbers
Telephone number or email address |



Printing Journals and Lists

Fax Parameter List

To Print a Fax Parameter List:

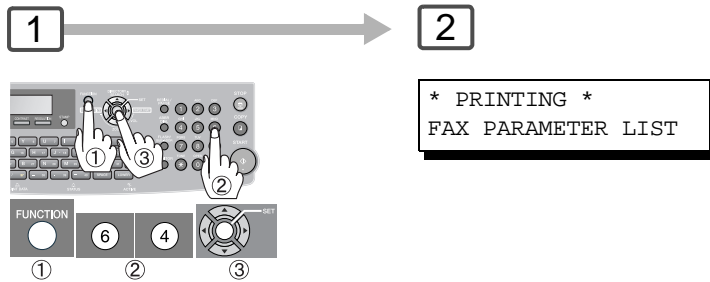

Sample Fax Parameter List

```

***** -FAX PARAMETER LIST- ***** DATE MMM-dd-yyyy ***** TIME 15:00 ***** P.01

(1)      (2)      (3)      (4)      (5)
PARAMETER DESCRIPTION SELECTION CURRENT STANDARD
NUMBER

(6)001   CONTRAST (HOME) (1:Lightest - 3:Normal - 5:Darkest) 3      3
*002     RESOLUTION (HOME) (1:Standard 2:Fine 3:S-Fine) 3      2
  )      )
  )      )
169      DHCP CLIENT (1:INVALID 2:VALID) 2      2

                                           -ABCD -

***** KM-F1060 ***** -HEAD OFFICE - ***** 201 555 1212- *****

```

Explanation of Contents

- | | | | |
|----------------------|---|----------------------|--|
| (1) Parameter Number | | (4) Current setting | : “----” indicates code or password is not set. |
| (2) Description | : “(HOME)” means home position setting. | (5) Standard setting | : Factory preset standard setting |
| (3) Selection | | (6) Changed setting | : “*” indicated that the Factory preset setting was changed. |



Problem Solving

Troubleshooting / Maintenance

If You Have Any of These Problems

Mode	Symptom	Possible Cause / Action	Page
During Transmission or Making Copies	Document doesn't feed/multiple feed	<ol style="list-style-type: none"> 1. Check that your document is free of staples and paper clips, and that it is not greasy or torn. 2. Check that your document is the right type to send through an ADF by consulting. 3. Check that the document is loaded properly. 	22
	Does not stamp (For Facsimile)	Check Fax Parameter No. 4 and No. 28 settings.	110 111
	Stamp too light (For Facsimile)	Replace stamp or refill ink.	137
Transmission Copy Quality or Copies Quality	Vertical lines on the transmitted/copied document	Check own copy quality. If copy is OK, your machine has no problem, report to the receiving party that they have a problem. If copy is NG, clean the Document Scanning Area.	--
During Reception or Making Copies	No recording paper	Replenish the recording paper.	26
	Recording paper misfed	Remove the misfed paper.	30
	Recording paper doesn't advance into machine	Make sure that there is paper in the Paper Tray. Follow the instructions for loading paper.	26
	Recording paper doesn't eject after printing	Check to see if the recording paper is jammed inside of the machine.	30
	Document auto reduction doesn't work	Check Print Reduction settings.	48
	Out of toner	Replace the Toner Container.	28
Communication	No dial tone	<ol style="list-style-type: none"> 1. Check the connection of the telephone line. 2. Check the telephone line. 	20
	No auto answer	<ol style="list-style-type: none"> 1. Check the connection of the telephone line. 2. Check the Reception mode setting. (Fax Parameter No. 17) 3. If the Fax Parameter No. 13 (Auto Journal Print) is set to "Valid" (default setting) and the machine is printing the received document(s) from memory, which also happens to be the 200th transaction, the machine will not automatically answer until the Transaction Journal completes printing. 	20 48
	Cannot transmit or receive	An information code will be shown on the display. Refer to the information code table to find out the trouble and solution.	134

Mode	Symptom	Possible Cause / Action	Page
No Machine Operation	No machine operation	To reset the machine, turn "Off" the Power Switch for a few seconds then turn it "On" again.	--

■ Machine Care

When lines or voids as shown in the example on the right appear on marked Copies/Scanned Images, the scanning area may be dirty.

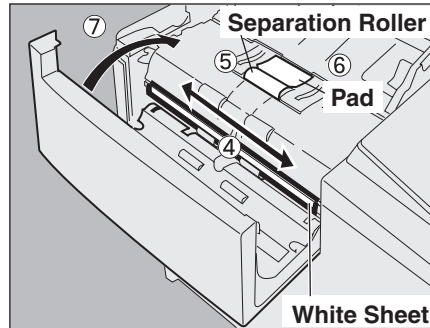
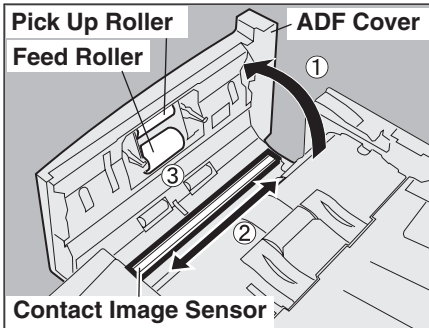
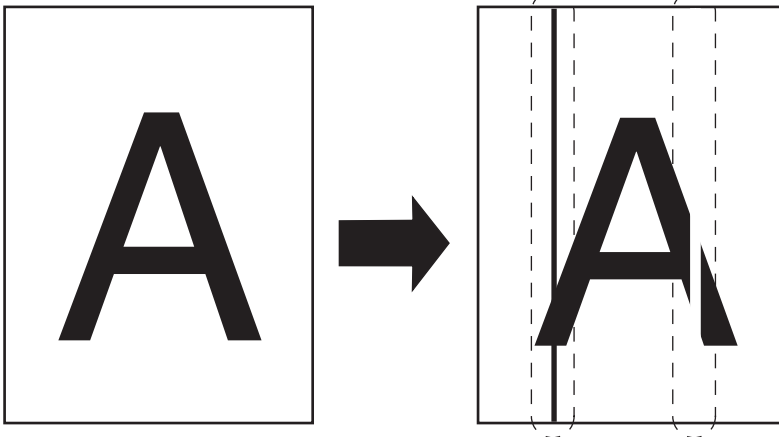

- ① Open the ADF Cover.
- ② Wipe marks off on the Contact Image Sensor with a dry soft cloth.
- ③ Clean the Pick Up/Feed Rollers with a well-wrung damp cloth (with water).

- ④ Wipe marks off on the White Sheet with a dry soft cloth.
- ⑤ Clean the Separation Roller with a well-wrung damp cloth (with water).
- ⑥ Clean the Pad with a soft dry cloth.
- ⑦ Close the ADF Cover.



Problem Solving

Information Code

When an anomaly occurs, the display may show one of the Information Codes listed below. These will help you to identify and correct the problem.

Info. Code	Meaning	Possible Action	Page
030	Document is misfeeding.	1. Reload the document properly. 2. Remove the document jam. 3. Adjust ADF.	30
031	Document is too long or jammed. Document length exceeds 39.4 inches (1 meter). The length limitation for 600 dpi, is subject to the available Memory size. 600dpi (Max. Length is 24 inches (600 mm))	1. Reload the document properly. 2. Remove the document jam.	30
061	ADF Cover is open.	Close the ADF Cover.	--
400	During initial connection, receiving station did not respond or communication error occurred.	1. Check with the other party. 2. Reload the document and send again.	--
402	During initial connection, communication error occurred.	Reload the document and send again.	--
403	No polling capability at the remote side.	Ask remote side to set "POLLED=ON".	--
404/405	During initial connection, communication error occurred.	Reload the document and send again.	--
406	Transmission Password does not match. Receiving Password does not match. Received from an unauthorized station in Selective Reception mode.	Check the password or the telephone number in One-Touch or Abbreviated station.	--
407	No confirmation from the receiving station for the previous page sent.	Wait a few minutes and send again.	--
408/409	Remote side confirms previous page(s) is(are) illegible.	Wait a few minutes and send again.	--
410	Communication aborted by the transmitting side.	Check with the other party.	--
411	Polling password does not match.	Check the polling password.	56
412	No data from the transmitting side.	Check with the other party.	--
414	Polling password does not match.	Check the polling password.	56
415	Polling transmission error.	Check the polling password.	56
416/417/ 418/419	Received data has too many errors.	Check with the other party.	--
420/421	Machine goes to receiving mode, but receives no command from the transmitting side.	1. Remote side misdial. 2. Check with the other party.	--
422/427	Interface is incompatible.	Check with the other party.	--
430/434	Communication error occurred while receiving.	Check with the other party.	--
436/490	Received data has too many errors.	Check with the other party.	--

Info. Code	Meaning	Possible Action	Page
456	<ul style="list-style-type: none"> • Machine received a confidential document or was requested to be polled of a confidential document under any of following conditions. 1. Not enough space in memory to receive the confidential document. 2. Confidential Mailbox is full. 3. While printing, the machine received a document. • Machine was requested to relay a document. 	<ol style="list-style-type: none"> 1. Print a File List and check the contents. 2. Wait until machine finishes printing. 	76
492/493/ 494	Communication error occurred while receiving.	Check with the other party.	--
495	Telephone line disconnected.	Check with the other party.	--
501/502/ 503/504	Communication error occurred using the internal V.34 Modem.	Check with the other party.	--
540/541/ 542/ 543/544	Communication error occurred while transmitting.	<ol style="list-style-type: none"> 1. Reload the document and send again. 2. Check with the other party. 	--
550	Telephone line disconnected.	Check with the other party.	--
552/553/ 554/555	Communication error occurred while receiving.	Check with the other party.	--
580	Sub-address transmission to a machine that has no Sub-address function.	Check the remote station.	62
581	Sub-address Password transmission to a machine that has no Password Sub-address function.	Check the remote station.	62
623	No document loaded on the ADF.	Reload the document and send again.	--
630	Redial was not successful due to a busy line.	Reload the document and send again.	--
631	During dialing, STOP was pressed.	Reload the document and send again.	--
634	<p>Redial was not successful due to no response from the called station or wrong number dialed.</p> <p>Note: If busy tone was not detected, the machine will only redial once.</p>	Check the telephone number and send again.	--
638	Power failure occurred during the communication.	Check the power cord and plug.	--
718	Page Memory Overflow occurred while receiving printing data. The paper size selected within your application to print is larger than the paper size loaded in the Paper Tray(s).	Check the document size and resolution. Ask sender to resend in a supported size and resolution.	--
730	Cannot retrieve the Journal nor program the Internet Parameters and the Auto Dialer remotely via email from a PC.	Check that the Fax Parameter No. 158 (PC Remote Update) is set to "Valid".	114
731	The dialer buffer for manual dialing was full (50 stations) when the Relay Transmission Request was received.	Request the sender to resend the Relay Transmission Request after the reserved communication is finished.	--

Continued on the next page...

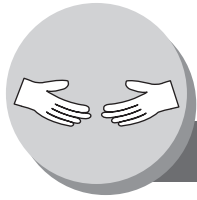

Problem Solving

Information Code

Info. Code	Meaning	Possible Action	Page
800/814/ 816/825	Machine was requested to relay a document or Confidential Communication but has no capability.	Check with the other party.	--
826	Received Sub-address is not registered in the Auto Dialer (One-Touch/ABBR. Dialing).	Check the Auto Dialer. Check the remote station.	--
870	Memory overflow occurred while storing documents into memory for transmission.	1. Transmit documents without storing them into memory first. Use Direct Transmission when using G3 Fax Communication. 2. Install Optional Memory (SD Memory Card).	42 140
871	Overflow of the file management area occurred.	Wait until the machine finishes printing or sending the documents.	--

NOTE

1. After identifying the problem and taking the recommended action, if the Information Codes keep reoccurring or Information Codes that appear on your machine but are not listed above, please contact your local Authorized Dealer.



Problem Solving

Verification Stamp

■ Verification Stamp

The Verification Stamp contains ink. When the stamp mark appears faded or hard to see, the stamp should be replaced or refilled with ink.

To remove the stamp

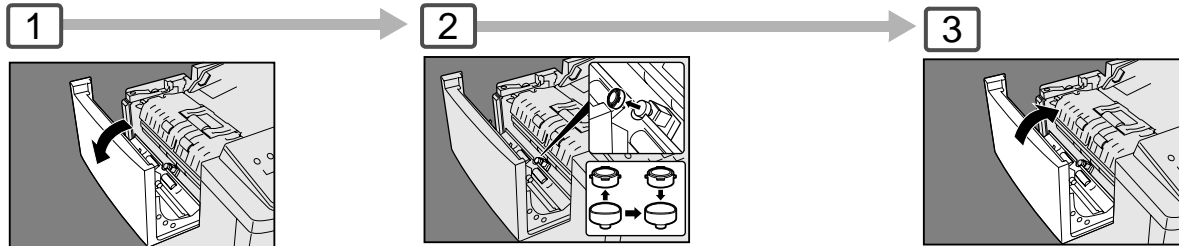

Open the ADF Cover

Remove the Stamp. Replace the stamp with a new one or refill the stamp with a few drops of the specified ink into the back of the stamp. (see Note 1)

Close the ADF Cover.

Verification Stamp Order No.: DZHT000027

■ Replacing the Battery

The machine has an internal battery (Product No.: CR2032) which maintains the date and time.

In the event the battery requires replacement, a message will be displayed.

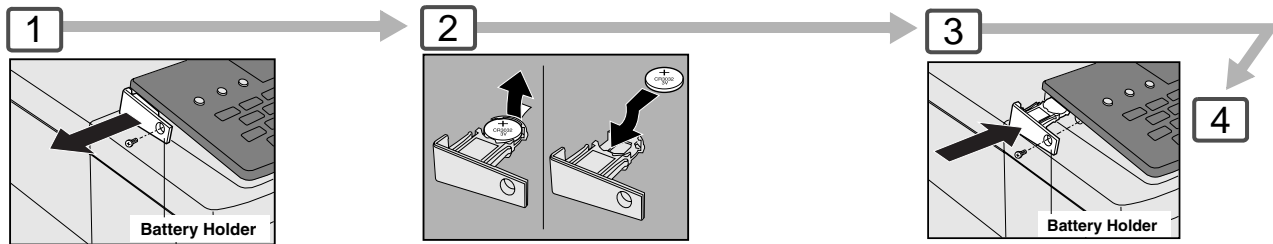
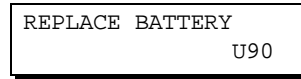

- ①: Turn the Power Switch on the Back Side of the machine to the OFF position.
- ②: Remove a Screw and the Battery Holder

"+" side of battery should be facing upwards. (Observe the polarity, see CAUTION! below)

- ①: Reinstall the Battery Holder and fasten the Screw.
- ②: Turn the Power Switch on the Back Side of the machine to the ON position.

- 4 If the clock is flashing on the LCD Display, follow the procedures on page 106 to reset the clock.

NOTE:
The service life of the battery is approximately 1 year under normal use.

⚠ CAUTION

denotes hazards that could result in minor injury or damage to the machine. THIS PRODUCT CONTAINS A LITHIUM BATTERY. REPLACE ONLY WITH THE SAME OR EQUIVALENT TYPE. "IMPROPER USE OR REPLACEMENT MAY CAUSE OVERHEATING, RUPTURE OR EXPLOSION RESULTING IN INJURY OR FIRE. DISPOSE OF USED BATTERIES ACCORDING TO THE INSTRUCTIONS OF YOUR LOCAL SOLID WASTE OFFICIALS AND LOCAL REGULATION"

⚠ CAUTION

Keep button battery/verification stamp and small parts out of reach of children to prevent choking or poisoning. If a button battery/verification stamp is swallowed accidentally, get medical treatment immediately.

NOTE

1. Please contact your local Authorized Dealer to purchase a new stamp.
2. Stamp ink refills can be purchased from a stationary store. Use blue Shachihata "X" Stamp ink (No. 22113) or its equivalent.



Appendix

Specifications

Type:	Desktop
Acceptable Originals	Sheets (Invoice - Legal size)
Copying Method	Laser Electrophotography
Scanning Method	Contact Image Sensor
Fusing Method	Heat Roller
Imaging Method	1 Component Non Magnetic Dry Toner Contact Developing
Resolution	Max. 600 dpi
Operation Panel	LCD Display
Copy Size	Legal - Letter via Paper Tray / Legal - Invoice via Sheet Bypass
Void Area	Max. 0.2" (5 mm)
Warm Up Time	Approx. 19 seconds (68°F/20°C)
First Copy Time	Approx. 19 seconds (Letter, from 1st Tray)
Multi-Copy Speed (Letter size)	18.5 cpm
Enlargement Ratios	101% to 141% in 1% increments
Reduction Ratios	99% to 71% in 1% increments
Paper Feed	Paper Trays (250 sheets (20lb) Standard + 550 sheets (20lb) Option) + Single Sheet Bypass •Transparency film should be loaded into the standard paper tray (Tray-1; up to 20 sheets) or use the Sheet Bypass (1 sheet).
Paper Weight	Paper Tray : 16 - 28 lb (60 - 105 g/m ²) [1-Sided Copy] 20 - 24 lb (75 - 90 g/m ²) [2-Sided Copy] Bypass : 16 - 44 lb (60 - 165 g/m ²)
Quantity Selector	Max. 999 sheets (Output Tray capacity is 150 sheets)
Electrical Consumption	AC 120V, 60Hz, 8A
Power Consumption	Transmission : Approx. 21 W Reception : Approx. 860 W Maximum : 1000 W
Dimensions (W x D x H)	17.7 x 16.5 x 17.6 inches (450 x 418 x 448 mm)
Mass (Weight)	48.5 lb (22 kg)
Operating Environment	Temperature: 50 - 86°F (10 - 30°C) [Humidity should be 70% or less at 86°F (30°C)] Relative Humidity: 30 - 80% [Temperature should be 80°F (27°C) or less at 80% RH]

*When used only with our recommended Letter size paper.

For G3 Facsimile

Compatibility	ITU-T Group 3
Coding Scheme	JBIG, MH, MR, MMR (Conforms to ITU-T Recommendations)
Modem Type	ITU-T V.34, V.17, V.29, V.27ter and V.21
Modem Speed	33600 - 2400 bps
Document Size	Invoice/A5 - Letter/A4 Max : 8.5 x 39.4 in (216 x 1000 mm) (with operator's assistance) Min : 5.5 x 8.5 in (Invoice)
Effective Scanning Width	8.3 inches (212 mm)
Scanner Resolution	Horizontal : 203 pels/inch (8 pels/mm) : Standard and Fine Resolution : 406 pels/inch (16 pels/mm) : Super Fine Resolution : 600 dpi : 600 dpi Resolution Vertical : 98 lines/inch (3.85 lines/mm) : Standard Resolution : 196 lines/inch (7.7 lines/mm) : Fine Resolution : 391 lines/inch (15.4 lines/mm) : Super Fine Resolution : 600 dpi : 600 dpi Resolution
One-Touch/Abbreviated Dialing Memory Capacity	200 Stations (ABBR No.) + 80 Stations (One-Touch or Program key)+ 50 Stations (Direct Dialing) (plus additional 720 stations with the optional SD Memory Card installed) Each station can register up to 36 digits for each telephone number (including pauses and spaces) and up to 15 characters for each station name.
Image Memory Capacity	Base Memory 720 pages (Based on ITU-T Image No.1 using Standard Resolution) (See page 147)
FCC Registration Number	US:E52FA32BUF-8000
Ringer Equivalence	3.2B

Continued on the next page...



Appendix

Specifications

ADF (Standard)

Tray Capacity	Letter, Invoice : 100 sheets (20 lb / 75 g/ m ²)
Paper Size	Invoice/Letter/Legal
Paper Weight	14 - 28 lb (50 - 105 g/ m ²)
Electrical Requirements	Supplied from the machine

2nd Paper Feed Module (PF-47) (Option)

Paper Size	Letter/Legal
Paper Weight	16 - 28 lb (60 - 105 g/ m ²) [1-Sided Copy] 20 - 24 lb (75 - 90 g/ m ²) [2-Sided Copy]
Electrical Requirements	Supplied from the machine
Dimensions (W x D x H)	17.7 x 15.1 x 5.5 inches (450 x 383 x 140 mm)
Mass (Weight)	11 lb (5 kg)

Options and Supplies

Part Name	Part No.	Remarks
2nd Paper Feed Module	PF-47	For Additional Paper Feeding (Tray-2)
G3 Communication Port Kit	MP-47	For Additional telephone line.
Handset Kit	HS-47	Telephone Handset Kit
Internet Fax/Email/Network Scanner Module	IF-47	For Network Scan and Email Function
Toner Container	TD-47	All in one container
SD Memory Card		<ul style="list-style-type: none"> • Only Genuine 32MB to 512MB SD Memory Card (with a SD trademark) can be used. • High speed data transfer type is recommended. • The SD Memory Card will be formatted to the proprietary format used in this machine. Please note that ALL the files will be lost after formatting. <p>Please contact your local authorized dealer for more details about purchase and installation of the SD Memory Card.</p>

memo



Appendix

Glossary

Access Code	A 4-digit programmable access code that prevents unauthorized operation of your machine.
ADF (Automatic Document Feeder)	The mechanism that delivers a stack of document pages to the scanner one page at a time.
Address Book	The ability to store full phone numbers or email addresses into the dialer and then utilizing a single keystroke to speed dial that number/email address in the future.
Address Book Dialing	The ability to dial an entire telephone number/email address by pressing one key.
Auto Print Reduction	The method of automatically reducing a received document so that it can be printed onto a standard size piece of plain paper. For example, your machine will reduce an incoming legal size page to 75% of its original size so it could fit on a letter size page.
Automatic Reception	The mode that allows you to receive fax documents without user intervention.
Batch Transmission	The ability to accumulate different document files for the same destination(s) to be transmitted in a single phone call.
BPS (Bits Per Second)	The amount of data that is transmitted over the phone line. Your machine can start at each Max. Modem speed and automatically steps down to suitable speed depending on the phone line condition and the receiving machines capabilities. (Max. Modem Speed is 33600 BPS)
CCITT	Consultative Committee on International Telegraph and Telephone. This organization has presently developed four groups of industry standards that insure facsimile compatibility.
Character ID	A programmed proprietary code name that allows up to 16 alphanumeric characters identifying your machine.
Character Keys	The keys that are used to enter letters and symbols for various programming functions.
Client	Clients are computers that run software programs used to contact and obtain data from Server software program on another computer, often across a great distance.
Coding Scheme	The data compression method used by facsimile machines. Your machine utilizes Modified Huffman (MH), Modified Read (MR), Modified Modified Read (MMR) and Joint Bi-level Image experts Group (JBIG) coding schemes.
Comm. Journal	Refers to either the Communication Journal (Comm. Journal), or Relay Transmission Report.
Contrast	Signifies the scanning sensitivity in terms of lightness and darkness of your original transmitting pages.
Cover Sheet	A Fax Cover Sheet can be attached to your transmit document(s) that shows the recipient's name, originator's name and number of pages attached.
DDD (Direct Distance Dialing)	A telephone service that allows unassisted dialing, no operator assistance is required.
Deferred Polling	The ability to retrieve documents from other stations at a later time.
Deferred Transmission	The ability to send documents to other stations at a later time.

Department Code	This operation require the user to input a preset 4-digit Department Code before transmission. The Department Name of selected Department Code is printed on the Header of each page sent, Cover Sheet, Comm. Journal and Individual Transmission Journal.
Direct Dialing	The method of dialing where you enter the entire telephone number or email address through the QWERTY keyboard.
Directory Search Dialing	Allows you to dial a full telephone number or email address by searching the station's name entered in the Address Book.
Directory Sheet	The list that contains the station names that are programmed into your machine.
DTMF (Dual Tone Multi-Frequency)	Dialing method that sends a different set of frequencies for each digit of the telephone keypad. Commonly refers to touch tone dialing.
Duplex Scan	The ability to scan both sides of 2-sided original(s) for transmission.
ECM (Error Correction Mode)	The ability to correct transmission errors as detected during the transmitting phone call.
End Receiving Station	In a relay network, the final station designated to receive the document.
Energy-Saver Mode	Saves energy by consuming less power than when in standby mode by turning off the fuser unit after the specified time.
Fax Forward	The ability to forward all incoming faxes to the specified station registered in the Address Book.
Fax Parameter List	The list that contains the home FAX parameters settings that you have programmed into your machine.
FAX/TEL Auto Switching	The ability to share a single telephone line for both fax and voice usage.
File	A task that has been stored into the memory of your machine. Examples are deferred transactions.
Fixed Print Reduction	The method that allows you to determine one reduction rate, such as 75%, for all incoming documents.
Function	The control panel key that will be utilized to begin an operation or configuration of a feature.
G3 Mode (Group 3)	Refers to the standards and transmission capabilities of the current generation of facsimile machines.
Group Dialing	The ability to program many telephone numbers and/or email addresses into a single station so that many locations can be dialed in sequence utilizing a single keystroke.
Handshaking	The exchange of a group of control signals that communicate between the transmitter and receiver. These signals determine the condition at which communication can occur.
Header	A row of information that is transmitted by the sending machine and printed on the top of each page by the receiving machine. This identifies the transmitting machine and information about the transmission, such as time and date.

Continued on the next page...



Appendix

Glossary

Image Memory Capacity	This signifies the amount of memory available in your machine to store pages of documents. Unit of measurement is based on the ITU-T Image No.1.
Index Keys	A series of alphabetized keys for easy access to the stations programmed in the Address Book.
Individual Transmission Journal	A report that is printed by the transmitter stating information regarding the last document transaction.
Information Code	A code that is internally generated by your machine stating a specific operational error or machine failure.
Initial Sending Station	In a relay network, the station that is originating the document transmission.
ITU-T	International Telecommunication Union - Telecommunication, formerly known as C.C.I.T.T.
ITU-T Image No. 1	An industry standard document that allows comparisons of the transmission speeds and capabilities of facsimile machines.
Journal	A report that is printed by your machine listing the last 200 transactions.
Key Name	An alternate to the station name that can be programmed for each Address Book dialing key. (By default it displays the first 15 characters of the station Name)
Keypad	A group of numeric keys located on your control panel.
LCD	Liquid Crystal Display. The display area of your machine.
LOGO	Your programmed company name or identification up to 25 alphanumeric characters.
Manual Reception	A mode that requires operator intervention to receive an incoming document.
Memory Transmission	The documents are scanned into memory before actual connection to the phone line for transmission.
Modem	A device that converts signals from your machine into signals that can be transmitted over telephone lines.
Multi-station Transmission	The ability to broadcast the same set of documents to a programmed number of locations.
Multiple Logo	The user can select one of 25 preset LOGOs before a transmission.
Off-Hook Dialing	The direct dialing of a telephone number with the handset out of the cradle or "off the hook".
On-Hook Dialing	The direct dialing of a telephone number with the handset in the cradle or "on the hook".
Overlap Printing	Documents too long to be reduced are automatically printed on two pages with approximately 0.5" (13 mm) overlap.
Super Smoothing	An electronic image enhancement (Super Smoothing) that will create a particular pattern for the improvement of copy quality.

Photo	A scanning technique to distinguish levels of gray from black and white. Your machine can detect up to 256 levels of gray in photo mode.
Polling	The ability to retrieve a document from another facsimile machine.
Polling Password	A 4-digit programmed code that enables the security of a document being polled.
Print Collation	The ability to stack received documents in the correct order.
Print Reduction Modes	The methods used to determine how an incoming document will be reduced to print onto the paper loaded in your machine.
Program Keys	Keys that are defined for storing a sequence of stations to be dialed or polled.
PSTN	Public Switched Telephone Network. Network of interconnected switching equipment and transmission facilities.
Qwerty Keyboard	A keyboard on the Control Panel that is used to enter letters and symbols for various programming functions.
Receiving Password	A 4-digit password is required to be entered before a document is received.
Relay Transmission Report	A report that contains information regarding the last relayed transmission.
Relayed Transmission	Sending a document to a relay station, which in turn, sends the document to the end receiving station.
Resolution	Relates to the number of dots scanned or printed per certain square. The quality of the image increases as the number of dots per certain square increases.
Selective Reception	A function that can be set so that your machine will receive from only those machines programmed into your dialer.
Sleep Mode	The lowest power state that the machine enters after the specified time without actually turning Off.
Station Name	Alphanumeric ID which can be programmed for each phone number/email address in the Auto Dialer.
Stored Documents	Documents that have been scanned and now are stored in your machine's memory.
Sub-address	ITU-T recommendation for further routing, forwarding or relaying of incoming faxes.
Sub-address Password	ITU-T recommendation for additional security that corresponds to the Sub-address.
Substitute Memory Reception	Your machine's ability to store an incoming document into its memory, when it runs out of recording paper or toner.
Transmission Password	A 4-digit password is required to be entered before a document is transmitted.
Transmission Reservation	The ability to preset a telephone number so that you may reserve a transmission while your machine is performing another function.

Continued on the next page...



Appendix

Glossary

User Parameter	Programmed parameters that provide information to other stations. Examples are logo, character ID, date and time.
Verification Stamp	A user selectable transmission verification stamp can be placed on scanned documents that are successfully transmitted or stored in memory.
View Mode - File List	Allows you to view the brief contents of the memory files through the LCD display without having to print the Memory File List.
View Mode - Journal	Allows you to view the brief contents of the journal through the LCD display without having to print the journal.

ITU-T Image No. 1

All specifications are based on the ITU-T Image No. 1 (The sample shown below is not to scale).



THE SLEREXE COMPANY LIMITED

SAPORS LANE - BOOLE - DORSET - BH 25 8 ER

TELEPHONE BOOLE (945 13) 51617 - TELEX 123456

Our Ref. 350/PJC/EAC

18th January, 1972.

Dr. P.N. Cundall,
Mining Surveys Ltd.,
Holroyd Road,
Reading,
Berks.

Dear Pete,

Permit me to introduce you to the facility of facsimile transmission.

In facsimile a photocell is caused to perform a raster scan over the subject copy. The variations of print density on the document cause the photocell to generate an analogous electrical video signal. This signal is used to modulate a carrier, which is transmitted to a remote destination over a radio or cable communications link.

At the remote terminal, demodulation reconstructs the video signal, which is used to modulate the density of print produced by a printing device. This device is scanning in a raster scan synchronised with that at the transmitting terminal. As a result, a facsimile copy of the subject document is produced.

Probably you have uses for this facility in your organisation.

Yours sincerely,

P.J. CROSS
Group Leader - Facsimile Research



Appendix

Index

Numerical		H	
2-Sided Receiving.....	49	Header Format	110
		Header Print	110
A		I	
Access Code.....	84	IFax Return Receipt.....	113
Adding Documents into a File	80	Image Memory Capacity.....	139
Automatic Document Feeder	142	Incomplete File Save	111
Automatic Reception.....	48	Information Code	134
Automatic Reduction.....	48	ITU-T Image No. 1	147
B		J	
Batch Transmission	52	Journals and Lists.....	122
C		M	
Canceling the Direct Transmission		Manual Reception.....	48
Reservation	43	Memory Transmissions	38
Changing or Erasing the Department Code	72	Mode Setting	34
Changing or Erasing the Settings of the One-Touch/ Abbreviated Dialing Numbers.....	104	Monitor Volume	94
Changing the Program Key Setting	60	O	
Changing the Start Time or the Station of a File.....	78	Off-Hook Dialing (Voice Mode Transmission)	46
Communication Journal (COMM. JOURNAL)....	124	One-Touch/Abbreviated and Directory Search List	126
Connecting the Cables.....	20	On-Hook Dialing	46, 144
Contrast	110	Operating FAX with the Access	84
Control Panel	36	Operating Instructions Outline	3
D		Operation Chart	22
Deferred Polling	50	Overlap Printing.....	144
Deferred Transmission.....	50	P	
Deleting a File	78	Pause	37
Department Code.....	70, 112	PIN Code Access	68
Diagnostic Password	111	Poll Documents from Another Station	56
Dial Prefix.....	86	Polling.....	54, 56
Dialing Method (Tone or Pulse)	94, 110	Preparing to be Polled	54
Dialing with a PIN Code	68	Print Reduction Setting.....	48
Document Size.....	139	Printing a Department Code Journal	74
E		Printing Documents	66
Edit File Mode	76	Printing Journals and Lists	122
Email Character Set.....	113	Printing or Viewing a List	76
Email Header Format.....	113	Printing Out a File	80
Entering Abbreviated Dialing Numbers.....	98	Printing the Directory Sheet.....	100
Entering One-Touch Dialing Numbers	98	Problem Solving	132
F		Program Keys	58, 60
Facsimile Features.....	38	Program List	128
Fax Cover Sheet.....	64	Programming Auto Dialer	96
Fax Parameter List.....	130	Q	
Fax Parameter Table	110	Quick Memory XMT	112
Fixed Reduction	48		
G			
Group Dialing	58		



R

Real-Time Batch Transmission 52
 Receive To Memory 66
 Received Time Print..... 110
 Receiving Documents 48
 Receiving Password..... 145
 Reduction Ratio..... 111
 Replacing Toner Container 28
 Resolution 110
 Retry an Incomplete File 82

S

Scanner Resolution..... 139
 Selecting the Access Method
 (Prefix or Suffix) 68
 Sending a Fax with Sub-Address 62
 Sending Document with Department Code 72
 Setting for Deferred Transmission 50
 Setting RCV To Memory Password 66
 Setting the Access Code..... 84
 Setting the Department Code..... 70
 Setting the Dialing Method (Tone or Pulse) 94
 Setting the Fax Parameters 108
 Setting the Monitor Volume 94
 Setting the RCV To Memory 66
 Setting the Ringer Volume 94
 Setting the Sub-Address into
 an Address Book 62
 Setting Your Machine 94
 Sub Address Password..... 112
 Sub-Addressing..... 62
 Substitute Memory Reception 48, 145

T

Timer Controlled Communications.....50
 To Stop the Transmission24
 Transaction Journal 114, 122
 Transmission Password.....145
 Troubleshooting132

U

User Parameter(s) 106, 146
 Using the Functions34

V

Verification Stamp..... 137, 146

The following trademarks and registered trademarks are used throughout this manual:

Adobe, Acrobat Reader & Adobe logo are either registered trademarks or trademarks of Adobe Systems Incorporated.

All other trademarks identified herein are the property of their respective owners.

For best results and machine performance, we recommend that you use only our original supplies for your products.



KYOCERA MITA AMERICA, INC.

Headquarters:

225 Sand Road,
Fairfield, New Jersey 07004-0008
TEL : (973) 808-8444
FAX : (973) 882-6000

New York Branch:

1410 Broadway 23rd floor
New York, NY 10018
TEL : (917) 286-5400
FAX : (917) 286-5402

Northeastern Region:

225 Sand Road,
Fairfield, New Jersey 07004-0008
TEL : (973) 808-8444
FAX : (973) 882-4401

Midwestern Region:

201 Hansen Court Suite 119
Wood Dale, Illinois 60191
TEL : (630) 238-9982
FAX : (630) 238-9487

Western Region:

14101 Alton Parkway,
Irvine, California 92618-7006
TEL : (949) 457-9000
FAX : (949) 457-9119

Southeastern Region:

1500 Oakbrook Drive,
Norcross, Georgia 30093
TEL : (770) 729-9786
FAX : (770) 729-9873

Southwestern Region:

2825 West Story Road,
Irving, Texas 75038-5299
TEL : (972) 550-8987
FAX : (972) 252-9786

National Operation Center & National Training Center:

2825 West Story Road,
Irving, Texas 75038-5299
TEL : (972) 659-0055
FAX : (972) 570-5816

Latin America Division:

8240 N.W. 52nd. Terrace Dawson Building,
Suite 108 Miami, Florida 33166
TEL : (305) 421-6640
FAX : (305) 421-6666

KYOCERA MITA CANADA, LTD.

6120 Kestrel Road, Mississauga,
Ontario L5T 1S8, Canada
TEL : (905) 670-4425
FAX : (905) 670-8116

KYOCERA MITA MEXICO, S.A. DE C.V.

Av. 16 de Septiembre #407
Col. Santa Inés,
Azcapotzalco México,
D.F. 02130, México
TEL : (55) 5383-2741
FAX : (55) 5383-7804